



State of North Carolina
General Court of Justice
Twenty-Sixth Prosecutorial District
MECKLENBURG COUNTY

R. ANDREW MURRAY
DISTRICT ATTORNEY

700 EAST TRADE STREET
CHARLOTTE, NC 28202
TELEPHONE: 704-686-0700
FAX: 704-686-0716

May 19, 2017

Chief Kerr Putney
Charlotte-Mecklenburg Police Department
601 East Trade Street, 3rd floor
Charlotte, NC 28202

Re: Josue Javier Diaz Death Investigation

Dear Chief Putney:

Pursuant to N.C.G.S. 7A-61, my office has reviewed the investigation surrounding the shooting death of Josue Javier Diaz on January 26, 2017. The case was investigated under complaint number 20170126131803. The purpose of this review was to examine whether the conduct of the undercover CMPD officer was unlawful. The officer will be identified here as **Officer UC**, which stands for **officer undercover**. In this case, the decedent raised a gun and fired at Officer UC after a traffic collision. Officer UC fired his weapon and killed Diaz. The use of deadly force by Officer UC was lawful under the laws of North Carolina.

This letter specifically does not address issues relating to tactics or whether officers followed correct police procedures or CMPD Directives.

I sent two senior Assistant District Attorneys to monitor the investigation into this shooting. One responded to the scene, and the second responded to the Law Enforcement Center to observe witness interviews. I personally reviewed the investigative file as provided by the CMPD. Finally, consistent with the District Attorney's Office Officer-Involved Shooting Protocol, this case was presented to the District Attorney's Homicide Team, which is comprised of the office's most experienced prosecutors.

A. The role of the District Attorney under North Carolina law

The District Attorney (DA) for the 26th Prosecutorial District is a state official and, as such, does not answer to city or county governments within the prosecutorial district. The DA is

the chief law enforcement official of the 26th Judicial District, the boundaries of which are the same as the County of Mecklenburg. The DA has no administrative authority or control over the personnel of the CMPD or other police agencies within the jurisdiction. That authority and control resides with each city or county government.

Pursuant to North Carolina statute, one of the DA's obligations is to advise law enforcement agencies within the prosecutorial district. The DA does not arrest people or charge people with crimes. When the police charge a person with a crime, the DA decides whether or not to prosecute the charged crime. Generally, the DA does not review police decisions not to charge an individual with a crime. However, in officer-involved shooting cases, the DA reviews the complete investigative file of the investigating agency. The DA then decides whether he agrees or disagrees with the decision made by the police. If the DA concludes that uncharged conduct should be prosecuted, the case will be submitted to a Grand Jury.

If no criminal charges are filed, that does not mean the District Attorney's Office believes the matter was in all respects handled appropriately from an administrative or tactical viewpoint. It is simply a determination that there is not a reasonable likelihood of proving criminal charges beyond a reasonable doubt unanimously to a jury. This is the limit of the DA's statutory authority in these matters. The fact that a shooting may be controversial does not mean that criminal prosecution is warranted. Even if the DA believes a shooting was avoidable or an officer did not follow expected procedures or norms, that does not make it criminal. In these circumstances, remedies (if any are appropriate) may be pursued by administrative or civil means. The DA has no administrative or civil authority in these matters. Those remedies are primarily in the purview of city and county governments, police departments and private civil attorneys.

B. Legal standards

The law recognizes an inherent right to use deadly force to protect oneself or others from death or great bodily harm. This core legal principle is referred to as the right to "self-defense." A police officer does not lose the right to self-defense by virtue of becoming a police officer. Officers are entitled to the same protections of the law as every other individual. An imminent threat to the life of a police officer entitles the officer to respond in such a way as to stop that threat.

Under North Carolina law, the burden of proof is on the State to prove beyond a reasonable doubt that a defendant did not act in self-defense. The Supreme Court of North Carolina defined the law of self-defense in State v. Norris, 303 N.C. 526 (1981). A killing is justified under North Carolina law if it appeared to a person that it was necessary to kill in order to save himself from death or great bodily harm. The law requires that the belief in the necessity to kill must be reasonable under the circumstances. Id. at 529.

C. Use of deadly force by a law enforcement officer

The same legal standards apply to law enforcement officers and private citizens alike. However, officers fulfilling their sworn duty to enforce the laws of this State are often placed in situations in which they are required to confront rather than avoid potentially dangerous people and situations.

The United States Supreme Court stated, “[t]he ‘reasonableness’ of a particular use of force must be judged from the perspective of a reasonable officer on the scene, rather than with the 20/20 vision of hindsight.” Graham v. Connor, 490 U.S. 386, 396 (1989). The Court further explained that “[t]he calculus of reasonableness must embody allowance for the fact that police officers are often forced to make split-second judgments – in circumstances that are tense, uncertain, and rapidly evolving – about the amount of force that is necessary in a particular situation.” Id. at 396–97.

D. Detailed report on the shooting of Josue Javier Diaz

The report below first details the accounts of the two individuals closest to the shooting; Officer UC and the passenger of the decedent’s truck, Javier Valiente. The report next details the information learned from the first officers to respond, the statements of civilian witnesses and forensic evidence.

I. Officer UC

Officer UC was interviewed by detectives on January 26, 2017, at CMPD headquarters. His account is detailed below and corroborated by other evidence. A transcript of the officer’s interview is attached as exhibit 1.

- Officer UC told detectives he was driving an unmarked, undercover vehicle and had just completed an undercover drug investigation. This information was corroborated by other detectives involved in the operation.
- Officer UC told detectives he was driving on Albemarle Road when he was sideswiped by another vehicle, which then fled the scene of the collision. This information is corroborated by:
 - The damage to both the undercover vehicle and the Nissan pickup driven by the decedent.
 - The statement of a fellow detective who Officer UC was on the telephone with when Officer UC told the detective he had just been sideswiped.
 - Radio traffic in which Officer UC notifies CMPD dispatch that he had been in an accident and that the other vehicle had fled the scene.
- Officer UC followed the vehicle that hit him until that vehicle abruptly stopped in traffic. Officer UC’s vehicle did not stop in time and bumped the decedent’s Nissan truck. This information is corroborated by:

- [Crime scene photographs](#) showing the two vehicles stopped in the roadway and showing that the two vehicles were touching.
- Officer UC explained the fatal encounter as follows:

“I jump out and immediately he jumps out, he says something to me in Spanish like ‘I’m gonna tell you something’ and that’s when I see the silver, looks to me like a four shooter .22 and he cocks it back, I wasn’t sure if it was single action or a double action so it’s probably a single action. So he pull it back and as he’s raising it, I drew, I engage. I think he got a shot off, I’m not a hundred percent sure.” This information is corroborated by:

 - [A small .22 revolver recovered at the scene.](#)
 - The gun was located [within arm’s reach of the decedent.](#)
 - The revolver had [spent cartridges](#) in it, indicating that it had been fired.¹
 - A close-up view of the weapon shows the [indentations](#) on the shell cartridges, indicating the rim-fire weapon was fired.
 - The revolver is a single action firearm, which means the decedent would have to “cock” the gun before firing.
 - The revolver appears to be the same gun the decedent posted a [photograph of on his Facebook page.](#)
 - Officer UC’s vehicle [door was struck](#) by a projectile consistent with a .22 caliber projectile.

II. Javier Valiente (*This witness used the name Javier Valiente when speaking with police and Jose Silvero when speaking to the media*)

Valiente was the passenger with the decedent in the Nissan pickup truck. He has given conflicting accounts to the police and the media. In addition, he discussed the events in a Facebook video viewed by thousands of people in which he gave yet another version.

Statement to detectives given by Valiente

This witness was interviewed on January 26, 2017, hours after the incident. The interview was conducted in Spanish. A transcript of Valiente’s interview is attached as exhibit 2.

- He told the detectives several different versions of the events. He initially told detectives that the SUV cut them off and denied that Diaz sideswiped the SUV. In the same interview, he admitted Diaz sideswiped the SUV and fled the scene.
- He told detectives that when both vehicles stopped, the person coming from the SUV shouted that he was a police officer and that Diaz got out of the car with his gun “in his pocket.”
- He also told detectives that Diaz always had the gun on the dashboard of the truck because Diaz knew he was not allowed to have a concealed firearm.

¹ There were four spent cartridges in the weapon. There is no scientific way to determine whether all of the rounds were fired during the encounter with Officer UC.

- Valiente also told detectives during the interview that Diaz was a citizen, had a gun and had a permit for the gun. He said Diaz “always had it because the police had always told him that since he has a permit he has to have it out in the open, in sight.” He described the gun as a “tiny, tiny pocket type,” chrome in color and as a .22 caliber. Valiente told detectives that he had seen this same gun before.
- Valiente said Diaz stopped his vehicle first on Albemarle Road. He opened his door and exited his vehicle to talk to the other driver. Valiente said “the other guy shouted that he was a police officer” when Diaz exited his own vehicle. When detectives asked Valiente for clarification, he reiterated that Officer UC said, “I’m police.”
- When asked what Diaz did when Officer UC said, “I’m police,” Valiente responded that Diaz did not draw his gun.
- Valiente said that when Diaz tried to talk to the other man, the other man “**ALSO** pulled out a gun, and started to shoot.” (Emphasis added. His use of the word “also” suggests that Diaz in fact drew his gun.)
- Valiente described to detectives that after Officer UC had “hit” his friend, the officer came over to him. Valiente was still in the truck. He repeated that Officer UC said he was a police officer.
- The detective asked Valiente, “So when Josue came out of the car, why did he grab the gun?” He responded, “Uh. Out of fear, I think; I don’t know.” This answer also suggests that Diaz did in fact draw his gun.
- Valiente also told the detectives he didn’t know whether Diaz had a gun in his hand when he got out of the truck.
- Valiente said Officer UC fired from inside his car and that he watched this in the rearview mirror.

Media accounts given by Javier Valiente

- On January 27, 2017, Valiente told the Charlotte Observer that when Diaz got out of his vehicle, the officer started to fire. He said that Diaz’s gun remained in the glove compartment the entire time. This is not what he told detectives.
- The same day, he told Fox 46 that when Diaz went up to the window of the SUV, the person started firing at him. In this interview, he stated Diaz was not carrying a gun because the gun was in the compartment “between the seats.” This is not what he told detectives, and the sequence of events he described to Fox 46 is not consistent with what he told the Observer.
- The next day, January 28, 2017, Valiente told WSOC-TV that Diaz’s gun was still in the truck when the officer fired on him. He denied that his friend, Diaz, had a gun in his hand when he was shot and claimed that Diaz stopped his truck and got out to apologize to the driver of the SUV, not knowing that he was an officer. He never told detectives that his friend was unarmed. He told them he didn’t know whether he had the gun in his hand and, at other times, suggested Diaz was in fact armed when he got out of the truck.

Facebook video version of events

- In a video posted on Facebook, Valiente stated the police “took me to the police station and they were asking me questions for about an hour, but I told them that I wasn’t going to tell them anything until I had an attorney.” *Note: the witness provided a video-taped interview to police detectives as described above.*
- Also during the video, Valiente stated, “I told him to call the ambulance but they never called them, and he laid there for an hour.” *Note: Medic was on scene within minutes.*
- Valiente said in the video that Officer UC never identified himself as a police officer, but in his recorded police interview, he said the opposite.
- Valiente claimed in the video that “the police officer took the firearm from the truck. Chesco [another name for Diaz] did not have the firearm on him, it was not on his body, I saw it all because I was in the truck.” However, in his police interview, he said he could not see whether Diaz had a gun when he was shot and admitted the gun was not in the truck after Diaz got out. There is no evidence to support his claim that the officer took the gun out of the truck.

In conclusion, the credibility of this witness suffers when weighed against the statements of the other witnesses, video, photographic and forensic evidence.

III. Responding officers

Officer Bumgarner:

- Officer Bumgarner was the first uniformed officer to respond. He had been parked in the Pizza Hut parking lot on Albemarle Road with his windows down when he heard five to six loud, consecutive shots.
- He pulled his marked patrol vehicle out onto Albemarle Road and saw that, just down the road, there was a man holding a person in a vehicle at gunpoint. Officer Bumgarner soon realized that it was an officer who was holding the person in the vehicle at gunpoint.
- Officer Bumgarner approached the passenger side of the vehicle where Officer UC was standing. He removed the passenger from the vehicle and asked Officer UC where the driver was. Officer UC responded and said, “‘He’s down, I shot him’ or something to that effect,” according to Officer Bumgarner.
- Officer Bumgarner approached the driver side of the vehicle and observed a firearm lying beside Diaz. He said it looked like a five shot, stainless steel Derringer revolver.

Sgt. Milliken:

- Sgt. Milliken was at his desk at the Eastway Division Office when he heard over the radio an officer provide his code number and say there was a “54,” meaning a hit and run, and that the car was not stopping. Sgt. Milliken described Officer UC as very calm over the radio and said there was no excitement in his voice. Officer UC provided his location, and Sgt. Milliken had other units respond.
- Sgt. Milliken then heard Officer UC say over the radio that shots had been fired and a person was down.

- When he arrived at the scene, Sgt. Milliken observed Diaz lying on the ground and what he described as a silver Derringer .22 revolver with a black handle lying within four feet of him. He said that the hammer was down, but he was unable to tell whether the weapon had been fired.
- Sgt. Milliken observed what appeared to be a bullet hole in the driver's door of the officer's SUV, but he did not know then whether it was from this incident or a prior incident.

Officer Innerfield:

- Officer Innerfield responded to the scene in his marked patrol vehicle from the Hickory Grove Division Office. He has extensive medical training and experience, so when he arrived, he went directly to Diaz, who was lying on the ground, in order to begin treatment.
- On his approach to Diaz, Officer Innerfield noticed a small silver revolver about two feet from Diaz's head. He described it as a very small revolver – a type that folds into a plastic handle.
- Officer Innerfield stood watch over Diaz and the firearm found on the ground until he was relieved by another officer. While he was standing there to keep the scene secure, Officer Innerfield noticed what he thought was a bullet hole in the SUV's driver side door.

Officer Littlejohn:

- Officer Littlejohn also responded to the scene. He approached the vehicles and observed Officer Bumgarner directing another officer to take control of the passenger from the pickup truck. Officer Littlejohn approached Diaz on the ground and observed a small pistol on the ground above Diaz's shoulders and head. He described it as a chrome-plated Derringer with brown, wooden grips.

IV. Civilian witnesses

Seven witness accounts are included below. It is noteworthy that parts of these accounts are consistent with each other and with the physical and scientific evidence, however, in some instances, witnesses observing the same events describe things quite differently. Some of the witness statements are inconsistent with the physical and scientific evidence. In evaluating the quality of a witness' statements, we use the same tests of credibility used in other cases. Among those tests are whether their statements are consistent with other credible evidence and whether the witness was in a position to see and hear what they reported. Comments below that point out inconsistencies or impossibilities are included to explain the extent to which we found a statement to be inaccurate.

Witness #1:

- This witness was interviewed by Detective Osorio on January 30, 2017.

- She came forward after hearing Officer Hernandez on Spanish Radio asking for witnesses to reach out to police.
- Witness #1 was traveling in the right lane on Albemarle Road when she saw what she described as a white pickup truck pass her. Following that truck was a dark colored SUV, which also passed her. She described both vehicles as traveling fast.
- As soon as both vehicles passed her, they came to a quick stop in the right lane, cutting her off. Witness #1 came to a stop directly behind the SUV. The white truck was directly in front of the SUV, and she observed the man in the truck exit first and “coming down to the truck.” Witness #1 told detectives the man from the white truck had a revolver in his right hand, down by his side, when he exited his truck.
- This witness saw the man in the SUV (Officer UC) open his [driver side door](#) and stay by the door. She believed that Officer UC must have seen the man with the gun.
- She told detectives Officer UC fired first and that the man from the white truck (Diaz) raised his gun and returned fire at the officer, and then the officer fired back. *Note: It is impossible from the physical evidence to determine who fired first.*
- This witness said the man from the white truck then fell down, and Officer UC went to the truck and pointed his gun at someone else in the truck until other officers arrived and took that person out of the truck.

Witness #2:

- This witness was first interviewed by Detective Lovell on January 26, 2017.
- This witness was stopped at the traffic light at Albemarle Road and Farm Pond Lane. He saw a car directly behind him at the light. He heard what he described as a “pap.” He looked out his side view mirror and saw the door on the vehicle behind him open. The witness said it appeared as though “he was gonna he had taken a shot at the car behind him.” It looked like he was going to try to get around behind the open door, according to this witness. The witness then heard “pap, pap, pap,” and he saw the person fall to the ground.
- It sounded to Witness #2 like there were two different caliber guns involved.
- He described the SUV as being behind the other car at an angle.
- Witness #2 stated that he left the scene, went to get a pint of whiskey and went home. He had a couple of drinks and then called the police about what he saw.
- Witness #2 was interviewed a second time on January 27, 2017, by Detectives Peacock and Lowe.
- In this interview, Witness #2 described being at the red light with two or three cars in front of him. He looked in his rear view mirror and the person directly behind him got out, and then he heard a pop. He looked in his side view mirror and saw the man was at first going toward the back of his car. Then, the witness saw another person get out and come around into the middle lane. At that time, he heard “pop, pop, pop.” He thought he heard five shots but was not certain about the count.
- He described a pause between the first shot and the four that followed. He also said they were two different sounds.

- Witness #2 was sure the man who got out of the SUV (Officer UC) was the man who shot the four rounds.
- He thought Officer UC was a white male and the other man was a black male.
- This witness said he could tell that the man from the second car behind him was a police officer due to his professionalism.
- The man in the car directly behind him (Diaz) got out first – before Officer UC – and headed toward the back of his car. The witness then heard the first pop, and he looked in his side view mirror and heard four or five more shots.

Witness #3:

- Witness #3 was interviewed by Detectives Ladd and Neblett on January 26, 2017.
- This witness owns a business near the scene of the incident. He was in the business' parking lot when he said he heard “fussing, yelling” and “loud voices.”
- He stated he then heard a gunshot. He said he knelt down, turned and looked back in the direction of the gunfire and then heard a minimum of four gunshots, possibly five.
- After the first gunshot, this witness said, he saw a brown SUV pull up behind a brown pickup truck, and somebody got out of the vehicle in the back (the SUV) and was “yelling and screaming” at whoever was in the truck in the front. *Note: All of the evidence suggests both vehicles were already stopped when the shooting occurred.*
- Witness #3 said that as the man exited the SUV, he pulled a pistol out of his shirt and “walked up and stormed up” to the car, and the next few shots came as he “stanced himself, he locked his, leveled his gun, and he let at least three or four more rounds go.”
- The witness heard four or five shots and then heard more screaming and saw one person walk around to the front corner of the truck, yell at somebody in the pickup truck and hold the gun at him. The witness then saw the man walk around to the center of the truck and point a gun at the front windshield. Then, an officer came out of the Pizza Hut parking lot.
- Witness #3 was armed with a firearm. He drew his weapon to assist the officer he saw arrive in the marked police SUV immediately after the shooting
- This witness stated that Officer UC’s SUV was touching the back of the truck.

Witness #4:

- Witness #4 was interviewed on January 26, 2017, at 3:10 p.m. by Detectives Koll and Jones.
- This witness was driving on Albemarle Road at Sharon Amity Road on the right side of the road when she noticed a pickup truck in the left lane. She described the pickup truck as speeding and then stopping hard to avoid hitting other cars. When they crossed over Sharon Amity Road, the pickup truck crossed over into the right lane without signaling, cutting another car off. The pickup truck then got back over into the left lane. The car in front of him was going too slow, so the pickup truck cut back over into the right lane again, and he cut off the man in the big truck.

- When the pickup truck cut over to the right lane, it made a screeching noise, which forced the man in the big truck to make the same noise with his car. She was unsure whether it hit the car in front of it.
- She stated that the man in the pickup truck got out first and looked as though he was going to approach the man in the big truck. He started walking toward the man in the big truck, but the vehicles were close together, so there was not far to go. He opened his mouth, but she did not hear any yelling.
- This witness said she could tell both men were mad. The man from the pickup truck was yelling, but she could not hear what he said. She could tell from his expression or reaction that the man from the big truck had said something to him.
- The witness said the man in the big truck (Officer UC) got out of his truck but remained on the running board of the vehicle, left the door open and started shooting at the man from the pickup truck.
- She heard two shots, and then the man from the pickup truck fell to the ground. She said the man from the big truck walked over and shot him again. *Note: None of the physical evidence is consistent with Diaz being shot while he was on the ground.*
- She said he shot at the man and then he came around to the other side of his truck to where he was on the sidewalk, with his gun still out, and knelt on the sidewalk.
- She saw a police car come from the Pizza Hut parking lot. That officer approached the man, and they struggled. *Note: This witness is likely referring to when the uniformed officer detained the pickup truck passenger.*
- Witness #4 described the decedent as a white male and Officer UC as a black male.
- She described being able to see all of the white male – even after the man from the big truck opened his door and stood on the ledge and in the doorway. She initially said her vision was not blocked but later clarified that the SUV door partially obscured her view of the individual who came from the small truck.

Witness #5:

- This witness was interviewed by Detectives Gonclaves and Jones on January 26, 2017.
- Witness #6 said he was in the waiting room at a service station on Albemarle Road when he heard five gunshots. He went outside and saw “the suspect” at the driver’s side window of the “victim’s” car. Almost immediately, he saw a police SUV arrive.
- He said the officer from the police SUV had his gun drawn but never fired.
- The witness reported seeing someone lying on the ground on the driver’s side of the pickup truck.

Witness #6, Ms. Addie Russell:

- Ms. Russell has identified herself as a witness in media accounts, and therefore her name is included in this report.
- She was interviewed by Detectives Ladd and Nesbit at 3:16 p.m. January 26, 2017.
- Ms. Russell was inside her business, which faces Albemarle Road. She was speaking with a customer when she heard gunshots. She walked out into the street and saw a man standing on the street with his gun pointed into a vehicle’s driver’s door. She described

hearing three shots first, and then she heard two or three more shots. Surveillance video from her business shows her [vantage point](#) when she left the store.

- She [recorded a video](#) on her cellphone after shots were fired. That video was reviewed as part of the investigation.
- Ms. Russell said she saw a man lying in the street, and she ran toward the scene. She saw a marked police car pull out of the U-Haul/Pizza Hut parking lot. She saw the officer “subdue” the person whom she believed shot into the pickup truck. *Note: The witness was initially certain that the person she saw being subdued was the shooter. After reviewing her video, it became apparent that the person subdued was actually Javier Valiente, Diaz’s passenger.*
- She estimated the distance from where she was when she walked out of her business to the scene to be about 150 to 200 feet; between six and eight car lengths.
- She described seeing a pickup truck and an SUV behind it. She saw the man with the gun standing on the driver’s side at the window of the truck. Ms. Russell described that man as “brown” (meaning he was not white) and having a beard.
- Ms. Russell said she saw a person (Diaz) slumping out of the driver side of the truck. She said the door was open, and he was hanging out from the shoulders on the ground. When she got closer, she saw the victim in the street. She said she never saw the shooter open the truck door but said that the door was closed when he was shooting. *Note: There is no forensic evidence to suggest Diaz was in the truck when he was shot. The [window to the truck](#) was partially raised, there are no projectile holes in the truck and her video shows the door to the truck closed.*
- Ms. Russell said the second round of shots took place before she started recording. She did not see Officer UC shoot. She just heard the shots.

Witness #7:

- This witness knew Diaz from previous interactions and happened to also witness the shooting.
- Witness #7 described Diaz as “pretty angry” when he got out of the car.
- This witness said Diaz went toward the SUV with a gun.
- The witness described Diaz as “aggressive” and that he “like to intimidate people with weapons.”
- Witness #7 also provided information that Diaz’s passenger, Javier Valiente, was threatened into making the Facebook video mentioned above.

V. Forensic evidence

The photographs of the firearm recovered at the scene are significant for several reasons. First, the gun matches the description of the gun described by Officer UC. Second, the gun appears to be the same gun as is pictured on the decedent’s Facebook page. Third, the gun had four fired rounds in the cylinder. And finally, the gun is a .22 caliber, which is consistent with a projectile removed from the door of Officer UC’s vehicle.

As detailed above, Crime Scene Search investigators photographed and processed both the decedent’s truck and Officer UC’s SUV. They documented a [bullet hole](#) to Officer UC’s

SUV. In addition, investigators recovered projectile material from the bullet hole found in the SUV. The projectile material recovered, along with the .22 caliber revolver, were submitted to the crime laboratory for examination.

Officer UC's gun was seized, and an ammunition count was done. Based on the count of ammunition, the officer fired his weapon six times. Four shell casings were recovered at the scene. The fact that the scene was a heavily travelled road and that cars passed through the scene before it was secured likely accounts for the absence of the other two shell casings.

The gun fired by Diaz was a revolver. There were four spent cartridges in the cylinder of the revolver. Revolvers do not eject shell casings. We do not know whether Diaz fired once or more than once. The witness accounts above could support either conclusion.

Crime laboratory reports

Chief Criminologist Gene C. Rivera concluded that Diaz's firearm was "found to be in good operating condition." His report regarding the examination of the projectile material concluded that the items "were examined and found to be .22 caliber." He was, however, unable to identify or eliminate the material as having been fired from the recovered .22 revolver. Rivera's report is attached as exhibit 3.

An examination for fingerprints was unsuccessful.

The recovered .22 caliber revolver was also examined by DNA Team Leader Eve Rossi. Rossi found the decedent's DNA on the grips of the firearm and also on the hammer of the firearm. Rossi's report is attached as exhibit 4.

Report of the Medical Examiner

Dr. James Lozano examined Diaz's body and determined Diaz was killed due to gunshot wounds to the chest and abdomen. Dr. Lozano detailed six gunshot wounds on the decedent's body. It is impossible to say for sure whether those gunshot wounds were caused by five or six bullets since one of the bullets could have caused two wounds. Prosecutors from my office met with Dr. Lozano to review the results of the autopsy.

Among the things they learned from Dr. Lozano is that the wounds are *not* consistent with Diaz being seated inside his truck when he was shot. Specifically, the wounds are consistent with Diaz being in a standing position outside of his truck, facing the officer when he was shot.

The Medical Examiner's Office also found cocaine and alprazolam (Xanax) in Diaz's system. Based on the levels detected, Diaz may have been under the influence of cocaine at the time of the shooting. Also based on the detected levels, it does not appear that Diaz was under the influence of the alprazolam during the encounter.

The Medical Examiner's report is attached as exhibit 5.

E. Responsible transparency

The undercover officer involved in this shooting has not been named in this report for a number of reasons. I have emphasized that I am a proponent of *responsible transparency*. As our community and the entire nation has become increasingly concerned about issues surrounding officer-involved shootings, my office's approach to these cases has evolved. Over the past year, it has become common practice for my office to provide the public with detailed reports containing analysis and evidence to more effectively communicate the facts of officer-involved shootings and the decision-making process used by this office. Responsible transparency is also the reason why this office has asked that evidence, including police videos, only be released after my prosecutors and I have completed a review of the investigation. This office has an obligation to protect the integrity of every investigation and, should someone be charged, preserve the defendant's right to a fair trial.

This report contains detailed, specific information and evidence gathered in the investigation, but this case presented extraordinary circumstances that caused my office to examine what it means to be responsibly transparent when balancing the public's right to know with threats against the safety of an officer, his family, other agents, witnesses and other civilians.

In the past, my office has at times withheld witness names for safety reasons. The decision to not publicly name the detective is also consistent with North Carolina public records law. Records of criminal investigations conducted by public law enforcement agencies are generally not public records. See [N.C. Gen Stat. § 132-1.4](#). There are a number of exceptions that are identified as public record, including the name of "a person arrested, charged, or indicted" and the name of a "complaining witness" ([N.C. Gen Stat. § 132-1.4\(c\)](#)). However, in this case, the detective is neither charged with a crime nor the complaining witness. Furthermore, laws surrounding employee personnel records state that, even if considered to be part of an employee's personnel file, "information that might identify an undercover law enforcement officer or a law enforcement informer" need not be disclosed ([N.C. Gen Stat. § 160A-168 \(c1\)](#)). While the officer is not an employee of the District Attorney's Office, the purpose of this provision (to protect the identity of undercover officers) is instructive.

Following this incident, law enforcement received information that Sureños 13 gang members were actively seeking out the identity of the detective in an attempt to locate him. Diaz had a number of tattoos that identify him as a member of Sureños 13. Regardless of whether or not he was actively involved in the gang around the time of his death, his identification as a gang member alone could cause Sureños 13 members to seek retaliation against the detective or his family.

Since the decedent's apparent gang ties played a role in the decision not to release the officer's name, I feel it is important to include the relevant information that associates Diaz with a gang in this report. The investigation clearly reveals Diaz has gang tattoos on his body, including "[Sureño Trece](#)" tattooed across his hands. Information and photographs downloaded from his phone further indicate [gang and drug involvement](#). Specifically, his cellphone

contained photographs of him with verified gang members², photographs of him and others [flashing gang](#) signs and at least 10 verified gang members listed as contacts. Diaz and Valiente, his passenger, are tagged in [Facebook photos](#) as members of Sureno Gangster Lokotes ([SGL](#)). His phone also contained pictures of illegal narcotics, as well as a [bullet-proof vest](#).

According to Gang Investigators with the North Carolina Department of Public Safety, a non-gang member who tattooed himself as a gang member would be met with harsh consequences from actual gang members. The street term is called “fronting,” or “false flagging.” “Fronting,” or identifying oneself as a gang member when he is not, is considered an insult to the gang and is usually met with violence.

Publicly identifying the detective could also result in danger to informants, sources and both state and federal law enforcement agents. This detective has worked in an undercover capacity for several years and continues to do so. Over time, he has introduced confidential informants into gangs and international criminal drug enterprises. He has infiltrated criminal organizations and then introduced other undercover officers – both CMPD and DEA officers – into those organizations to develop cases. If his name and therefore his identity as an undercover detective is revealed, it is a reasonable concern that the parties involved in these criminal activities could seek retribution against him and any people – undercover officers and civilian informants alike – who fall under suspicion because they were introduced into the enterprise by the detective. Both the DEA and CMPD have informed this office that releasing the detective’s name, and consequently publicizing his identify, would endanger civilians and law enforcement who have worked with him. That risk is unacceptable.

I firmly believe in the importance of public trust and access to information so that individuals can make their own analysis of the facts in officer-involved shootings. However, the public’s right to know must be balanced against the potential danger to people in the community. Based on the extraordinary circumstances surrounding this case, I believe that the danger of disclosing the officer’s identity outweighs other considerations.

The District Attorney’s Office is charged with protecting the people of Mecklenburg County. I cannot in good faith release information that may directly endanger the lives of police officers, federal agents and civilians. That would not be responsible transparency in this case.

Because the detective’s identity is being withheld at this time, this office believed it was appropriate to take additional steps to scrutinize his previous conduct as a CMPD officer. We obtained access to the detective’s entire personnel file and CMPD Internal Affairs file. This was done to determine whether there were any patterns of behavior in the detective’s files leading up to the shooting on January 26, 2017. No such behavior was found.

² The members are documented gang members according to validated, standardized criteria used statewide by law enforcement.

I. Gang affiliation

While discussed in the section above, I specifically conclude that the officer had no information regarding any gang affiliation of the decedent in this matter. Therefore, information about gang affiliation was not considered in determining whether the officer's conduct was lawful. During discussions of the facts of this investigation, neither I nor any of the prosecutors assigned to review this matter discussed or considered information related to any gang affiliation of Diaz.

F. Conclusion

There is no dispute that Officer UC fired his weapon and killed Diaz. Therefore, the central issue in this review is whether or not Officer UC was justified under North Carolina law in using deadly force. A police officer or any other person is justified in using deadly force if the officer reasonably believed, and in fact believed, that he or another person was in imminent danger of great bodily injury or death from the actions of the person who is shot. In this case, the evidence clearly supports the conclusion that Diaz was armed with a firearm and aggressively approaching Officer UC when the officer fired his weapon. Consequently, Officer UC was completely justified in using deadly force to stop the attack and prevent his own death. Therefore, I have determined not to seek charges against Officer UC.

If you have any questions, please contact me directly.

Sincerely,

A handwritten signature in black ink, appearing to read "R. Andrew Murray". The signature is fluid and cursive, with a long, sweeping underline that extends to the right.

R. Andrew Murray
District Attorney

Exhibits

Firearm recovered at scene

[\(Return to text\)](#)



Diagram of crime scene

[\(Return to text\)](#)

2017-0126-1318-03
6200 Albemarle Rd
CSI R.Vasale #4745
Not to scale

V1: Chevrolet TAHOE
V2: Nissan FRONTIER

A: discharged WIN 40 S&W cartridge case - CMPD Officer
B: discharged WIN 40 S&W cartridge case - CMPD Officer
C: discharged WIN 40 S&W cartridge case - CMPD Officer
D: discharged WIN 40 S&W cartridge case - CMPD Officer

E: silver North American Arms .22 Long Rifle Revolver
F: golden yellow Mitchell & Ness snapback hat embroidered with "Golden State Warriors"
G: prescription medication bottle for Hydrocodon-Acetaminophen
L: black/red Mitchell & Ness one size snapback hat embroidered with "Houston Rockets"

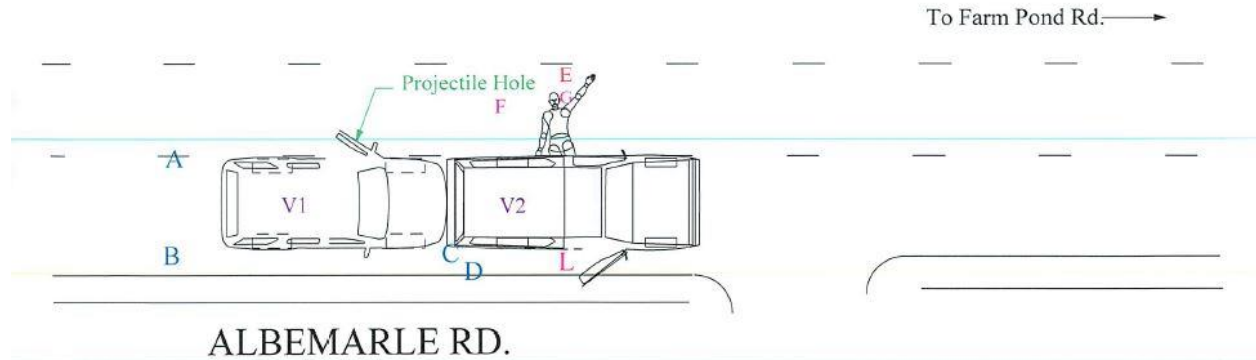

Photograph of firearm showing the cartridges in the cylinder

[\(Return to text\)](#)



Close-up photograph of discharged rim-fire cartridges

[\(Return to text\)](#)



Photo from Diaz's Facebook

[\(Return to text\)](#)



Close-up of projectile hole in SUV door

[\(Return to text\)](#)



Projectile hole in SUV

[\(Return to text\)](#)





Crime scene photograph showing window of the pickup truck partially rolled up and no projectile damage to the truck. [\(Return to text\)](#)



Video still shot from the surveillance camera at Ms. Russell's business. The top circle shows the officer pointing his gun at the truck. The lower circle shows Ms. Russell leaving the store and going to the location where she took video with her phone. [\(Return to text\)](#)



The video did NOT capture the actual shooting.

Still capture from video take by Ms. Russell on her phone

[\(Return to text\)](#)



Photos from cellphone and Facebook:

[\(Return to text\)](#)



Photos from phone

[\(return to text\)](#)



Photo from Facebook with Diaz and passenger Valiente

[\(Return to text\)](#)

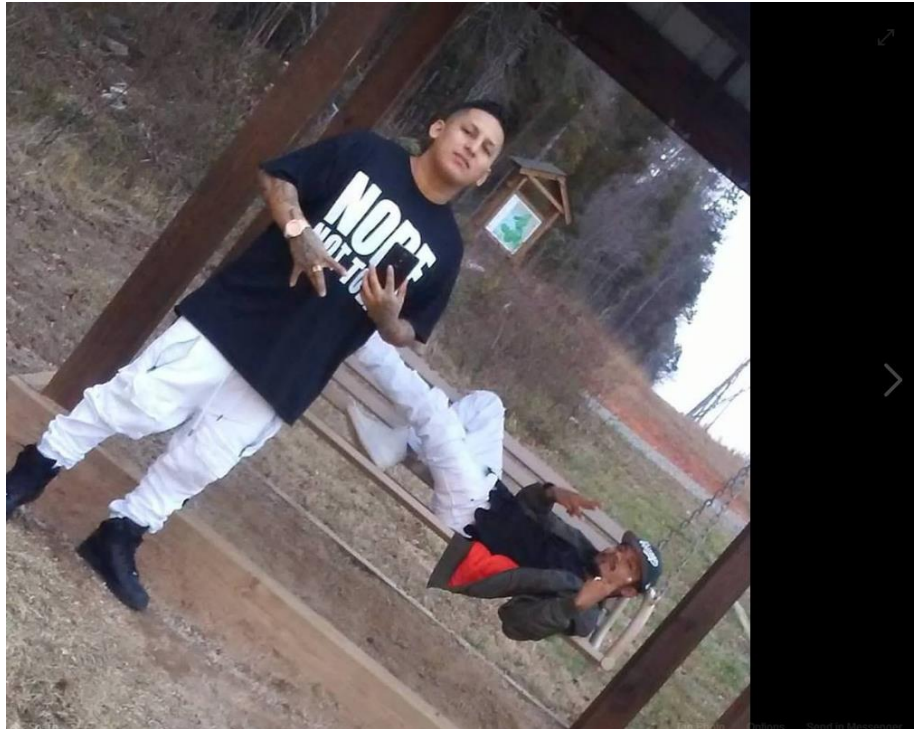

Benjamin Freestacks
February 17 · 🌐
[View on Instagram](#)

Happy G Day to my set brother muafucken chesco one of the realest out here S.G.L. for life — with Javier Diaz and Juan Jose Silverio.

Like Comment Share

👍❤️👍 67

Elizabeth Diaz Let's come out and light up lanterns for him!!!
Like Reply · February 17 at 7:47pm

Elizabeth Diaz Right now!!!
Like Reply · February 17 at 7:48pm

Benjamin Freestacks Yea I'm gona try to make it asap
Like Reply · February 17 at 8:03pm

Juan Jose Silverio Damn bro
Like Reply · February 17 at 8:33pm

Write a comment...
Press Enter to post.

Suggested Groups

The Untouchable™ Playhouse
2 friends · 130,643 members
[+ Join](#)



Ese Skipper
July 23, 2016 · 🌐

With Benjamin Freestacks, Juan Jose Silverio and Javier Diaz.

Like Comment Share

👍❤️👍 Juan Jose Silverio and 17 others

Write a comment...
Press Enter to post.

Suggested Groups

The Untouchable™ Playhouse

Somos SGL

[\(Return to text\)](#)



 **Javier Diaz**
June 4, 2016 · 🌐

🔗 Share

👍 9

 **Cruz Flores #carnales**
June 4, 2016 at 5:15pm

 **Ese Skipper Somos SGL**
June 4, 2016 at 7:13pm

Suggested Pages

 **The TANK**
Kimberly likes this
[👍 Like](#)

Sureño Trece:

[\(Return to text\)](#)



 **Javier Diaz**
December 19, 2016 · 🌐

➦ Share

👍❤️ 25

Exhibit 1

Charlotte Mecklenburg Police Department Supplement Report @				COMPLAINT NUMBER 20170126131803	Page # 1 of 57
2. Victim Name Josue Javier Diaz			3. Original Offense / Charge OIS		
4. Location Of Offense 6200 Albemarle Road			5. Arrest Number	6. C.R. Number	
7. Original Report Date 01-26-2017	8. Supplement Date 01-27-2017		9. Correct Incident Classification		
10. Juvenile Case No	11. Multiple Case Clearance No	12. Supplement Confidential Yes	13. Purpose Of Supplement Interview with Detective [REDACTED]		

THIS IS IN REFERENCE TO COMPLAINT NUMBER 20170126131803. THE DATE IS 1/27/2016; CURRENT TIME ,UH, 1605 HOURS. PRESENT IS DETECTIVE HEFNER, UH, WITH CMPD HOMICIDE, UH, DETECTIVE SERGEANT J.D. FURR WITH CMPD HOMICIDE; UH, ATTORNEY GEORGE LAUGHRUN AND [REDACTED]

Furr: Um, alright, uh Detective [REDACTED] we've...we spoke uh both yesterday and a little bit today and I just wanted to remind you that this is a uh...a separate but parallel investigation, okay, uh ongoing with our division, the Violent Crimes division, uh, Homicide and ADW as well as the Internal Affairs Division. Do you understand that?

[REDACTED] Yes.

Furr: Do you also understand that you are not under arrest and you don't have to talk to us. Uh you came here to talk to us voluntarily.

[REDACTED] Yes.

Furr: Are we in agreement?

[REDACTED] <Inaudible>

Furr: Okay. We're gonna go ahead and get started...

(Inaudible – [REDACTED] whispering with Laughrun)

[REDACTED] Yes.

Furr: Okay.

Hefner: You're alright.

21. UCR Clearance Status <input type="checkbox"/> Open <input type="checkbox"/> By Arrest <input type="checkbox"/> Exceptional <input type="checkbox"/> Unfounded		23. Reporting Officer M.L. Hefner	Code Assignment 4764 Homicide	Date 01-27-2017
22. Investigative Status <input type="checkbox"/> Active <input type="checkbox"/> Inactive <input type="checkbox"/> Closed <input type="checkbox"/> Administrative		25. Case Referred To	26. Reviewing Supervisor, Code, Date	

Charlotte Mecklenburg Police Department Supplement Report @				COMPLAINT NUMBER 20170126131803	Page # 2 of 57
2. Victim Name Josue Javier Diaz			3. Original Offense / Charge OIS		
4. Location Of Offense 6200 Albemarle Road			5. Arrest Number	6. C.R. Number	
7. Original Report Date 01-26-2017		8. Supplement Date 01-27-2017		9. Correct Incident Classification	
10. Juvenile Case No	11. Multiple Case Clearance No	12. Supplement Confidential Yes	13. Purpose Of Supplement Interview with Detective [REDACTED]		

Furr: Detective Hefner is going to ask you a few questions, it is a standardized form it's called an Officer Involved Shooting Form. It's what we complete on every officer involved shooting incident, okay. Uh once we go through those questions and answers uh then we will move onto the interview and you will tell us, uh, your account of yesterday's events.

[REDACTED] Okay.

Hefner: Alright um... I'm just writing the address on here as we determined it yesterday, I have 6200 Albemarle Road, uh, we used the Pizza Hut address cause we're so close to it. And Detective, if you would, I know I've already asked it from you, but if you would just state your full name please.

[REDACTED] [REDACTED]

Hefner: Okay and your code number?

[REDACTED] [REDACTED]

Hefner: And your date of hire?

[REDACTED] [REDACTED]

Hefner: [REDACTED]

[REDACTED] Yes sir.

Hefner: Okay.

21. UCR Clearance Status Open <input type="checkbox"/> By Arrest <input type="checkbox"/> Exceptional <input type="checkbox"/> Unfounded <input type="checkbox"/>		23. Reporting Officer M.L. Hefner	Code Assignment 4764 Homicide	Date 01-27-2017
22. Investigative Status Active <input type="checkbox"/> Inactive <input type="checkbox"/> Closed <input type="checkbox"/> Administrative <input type="checkbox"/>		25. Case Referred To	26. Reviewing Supervisor, Code, Date	

Charlotte Mecklenburg Police Department Supplement Report @				COMPLAINT NUMBER 20170126131803	Page # 3 of 57
2. Victim Name Josue Javier Diaz			3. Original Offense / Charge OIS		
4. Location Of Offense 6200 Albemarle Road			5. Arrest Number	6. C.R. Number	
7. Original Report Date 01-26-2017		8. Supplement Date 01-27-2017		9. Correct Incident Classification	
10. Juvenile Case No	11. Multiple Case Clearance No	12. Supplement Confidential Yes		13. Purpose Of Supplement Interview with Detective [REDACTED]	

[REDACTED] I don't know the specific date.

Hefner: Okay.

[REDACTED] <Inaudible>

Hefner: Uh do you have any prior law enforcement or military experience before that?

[REDACTED] I do.

Hefner: You do? Okay, what's your experience?

[REDACTED] I was uh...Airborne infantry.

Hefner: Okay.

[REDACTED] With the Army.

Hefner: Um, how many years if you remember?

[REDACTED] I did three years there, but I'm still in the Reserves.

Hefner: Still in the Reserves now?

[REDACTED] I went...on my primary I went to Iraq in 06 and 07 as an infantryman.

Hefner: Okay.

[REDACTED] Then I got deployed again to Fort Jackson for Drill Sergeant...Drill Sergeant duty, then I came back. And now I'm in the [REDACTED]

21. UCR Clearance Status <input type="checkbox"/> Open <input type="checkbox"/> By Arrest <input type="checkbox"/> Exceptional <input type="checkbox"/> Unfounded		23. Reporting Officer M.L. Hefner	Code Assignment 4764 Homicide	Date 01-27-2017
22. Investigative Status <input type="checkbox"/> Active <input type="checkbox"/> Inactive <input type="checkbox"/> Closed <input type="checkbox"/> Administrative		25. Case Referred To	26. Reviewing Supervisor, Code, Date	

Charlotte Mecklenburg Police Department Supplement Report @			COMPLAINT NUMBER 20170126131803	Page # 4 of 57
2. Victim Name Josue Javier Diaz		3. Original Offense / Charge OIS		
4. Location Of Offense 6200 Albemarle Road		5. Arrest Number	6. C.R. Number	
7. Original Report Date 01-26-2017	8. Supplement Date 01-27-2017	9. Correct Incident Classification		
10. Juvenile Case No	11. Multiple Case Clearance No	12. Supplement Confidential Yes	13. Purpose Of Supplement Interview with Detective [REDACTED]	

Hefner: Okay, alright um, your uh current division assignment, what's that?

[REDACTED] I'm with ... I'm part of the... [REDACTED] but... I don't know the exact...

Hefner: No, no not... I'm... I'm sorry, not the Army...

[REDACTED] Oh.

Hefner: ...what's you're a part of right now.

[REDACTED] Oh I'm sorry <Talkover - inaudible>

Hefner: Here at the department.

[REDACTED] I'm with the Vice and Narcotics Division, or the Covert Operations... They changed the name to it.

Hefner: That's alright <Talkover - inaudible>

Furr: When you started talking I was like <Inaudible>... this is something I've never heard of, what is this <Talkover - inaudible>

[REDACTED] <Talkover - inaudible>

Hefner: <Talkover - inaudible>... that's alright, no no problem... no problem, you said Vice and Narcotics and you said they changed the name what's the... what's the name as you know it now?

[REDACTED] Covert Operations.

21. UCR Clearance Status <input type="checkbox"/> Open <input type="checkbox"/> By Arrest <input type="checkbox"/> Exceptional <input type="checkbox"/> Unfounded		23. Reporting Officer M.L. Hefner	Code 4764	Assignment Homicide	Date 01-27-2017
22. Investigative Status <input type="checkbox"/> Active <input type="checkbox"/> Inactive <input type="checkbox"/> Closed <input type="checkbox"/> Administrative		25. Case Referred To	26. Reviewing Supervisor, Code, Date		

Charlotte Mecklenburg Police Department Supplement Report @			COMPLAINT NUMBER 20170126131803	Page # 5 of 57
2. Victim Name Josue Javier Diaz		3. Original Offense / Charge OIS		
4. Location Of Offense 6200 Albemarle Road		5. Arrest Number	6. C.R. Number	
7. Original Report Date 01-26-2017	8. Supplement Date 01-27-2017	9. Correct Incident Classification		
10. Juvenile Case No	11. Multiple Case Clearance No	12. Supplement Confidential Yes	13. Purpose Of Supplement Interview with Detective [REDACTED]	

Hefner: Covert Operations? Okay. Uh your shift and that's probably gonna make you smile, do you have a regular shift?

[REDACTED] For the most part yes <Talkover - inaudible>

Hefner: Okay what's that?

[REDACTED] ... 10 to 8.

Hefner: 10 to 8... to 8 p.m.?

[REDACTED] 10 a.m. to 8 p.m... I work um Tuesday through Friday's and de... depending on the investigation we might adjust that but for the most part those are our hours.

Hefner: Okay. Uh you have a radio call sign?

[REDACTED] [REDACTED]

Hefner: [REDACTED]

[REDACTED] [REDACTED]

Hefner: [REDACTED] Okay. Uh are you on a specific radio talk group?

[REDACTED] Most of our operations happen on Vice One but it depends, some... when we go into another district, they like... they prefer to use a local channel <Talkover - inaudible>

Hefner: Like a Tac channel or something like that?

[REDACTED] Yeah.

21. UCR Clearance Status <input type="checkbox"/> Open <input type="checkbox"/> By Arrest <input type="checkbox"/> Exceptional <input type="checkbox"/> Unfounded		23. Reporting Officer M.L. Hefner	Code 4764 Homicide	Assignment 01-27-2017	Date
22. Investigative Status <input type="checkbox"/> Active <input type="checkbox"/> Inactive <input type="checkbox"/> Closed <input type="checkbox"/> Administrative		25. Case Referred To	26. Reviewing Supervisor, Code, Date		

Charlotte Mecklenburg Police Department Supplement Report @			COMPLAINT NUMBER 20170126131803	Page # 6 of 57
2. Victim Name Josue Javier Diaz		3. Original Offense / Charge OIS		
4. Location Of Offense 6200 Albemarle Road		5. Arrest Number	6. C.R. Number	
7. Original Report Date 01-26-2017	8. Supplement Date 01-27-2017	9. Correct Incident Classification		
10. Juvenile Case No	11. Multiple Case Clearance No	12. Supplement Confidential Yes	13. Purpose Of Supplement Interview with Detective ████████	

Hefner: Okay uh, who's your supervisor?

████████ Sgt. Chad Howard. He writes my PRD so he's one of them and the other one is uh Billy Carey and before that it was Shane Edmonds.

Hefner: Okay, alright.

████████ But currently it's Carey and Howard.

Hefner: Okay um and when... yesterday when this occurred your uniform you were wearing, I'm assuming plain clothes.

████████ Uh plain clothes, was wearing a hoodie, a tee shirt, and jeans.

Hefner: Alright uh how tall are you?

████████ I'm 5'7.

Hefner: And about how much do you weigh?

████████ Bout 220.

Hefner: Uh how much sleep had you had the night or the day before this?

████████ Uh, a normal eight hours.

Hefner: Uh did you have any uh off duty at all prior to your shift?

████████ I did not.

Hefner: Uh the vehicle number you were in?

21. UCR Clearance Status <input type="checkbox"/> Open <input type="checkbox"/> By Arrest <input type="checkbox"/> Exceptional <input type="checkbox"/> Unfounded		23. Reporting Officer M.L. Hefner	Code Assignment 4764 Homicide	Date 01-27-2017
22. Investigative Status <input type="checkbox"/> Active <input type="checkbox"/> Inactive <input type="checkbox"/> Closed <input type="checkbox"/> Administrative		25. Case Referred To	26. Reviewing Supervisor, Code, Date	

Charlotte Mecklenburg Police Department Supplement Report @					COMPLAINT NUMBER 20170126131803	Page # 7 of 57
2. Victim Name Josue Javier Diaz				3. Original Offense / Charge OIS		
4. Location Of Offense 6200 Albemarle Road				5. Arrest Number		6. C.R. Number
7. Original Report Date 01-26-2017		8. Supplement Date 01-27-2017		9. Correct Incident Classification		
10. Juvenile Case No	11. Multiple Case Clearance No	12. Supplement Confidential Yes		13. Purpose Of Supplement Interview with Detective [REDACTED]		

[REDACTED]

No idea.

Hefner:

Okay um... I'll write unknown and uh... it was ... you were the driver of the vehicle?

[REDACTED]

Yes.

Hefner:

Okay and it is a city vehicle?

[REDACTED]

Yes.

Hefner:

Okay uh I'm gonna write uh ... it doesn't ask for a description but where I'm writing unknown I'm gonna put Tahoe cause that's...

[REDACTED]

It's a gold Tahoe.

Hefner:

Okay.

[REDACTED]

1999.

Hefner:

Okay. Is that your normal vehicle or is that one you guys share?

[REDACTED]

It's a spare.

Hefner:

Okay and it is not a marked vehicle, is that correct?

[REDACTED]

No.



Hefner:

Alright did you have any passengers?

[REDACTED]

Nope.

21. UCR Clearance Status <input type="checkbox"/> Open <input type="checkbox"/> By Arrest <input type="checkbox"/> Exceptional <input type="checkbox"/> Unfounded				23. Reporting Officer M.L. Hefner	Code Assignment 4764 Homicide	Date 01-27-2017
22. Investigative Status <input type="checkbox"/> Active <input type="checkbox"/> Inactive <input type="checkbox"/> Closed <input type="checkbox"/> Administrative				25. Case Referred To	26. Reviewing Supervisor, Code, Date	

Charlotte Mecklenburg Police Department Supplement Report @				COMPLAINT NUMBER 20170126131803	Page # 8 of 57
2. Victim Name Josue Javier Diaz			3. Original Offense / Charge OIS		
4. Location Of Offense 6200 Albemarle Road			5. Arrest Number	6. C.R. Number	
7. Original Report Date 01-26-2017	8. Supplement Date 01-27-2017		9. Correct Incident Classification		
10. Juvenile Case No	11. Multiple Case Clearance No	12. Supplement Confidential Yes	13. Purpose Of Supplement Interview with Detective 		

Hefner: Uh was there a DMVR?

: Nope.

Hefner: Uh your uh duty weapon, what... what duty weapon do you carry?

: An MP-40 Compact.

Hefner: Um and I'll... I'll get the serial number out of my notes unless you know it off the top of your head.

: I do not.

Hefner: Okay, okay I don't... I don't know that I know mine either. Bear with me.

Furr: You want the serial?

Hefner: Yeah, let me get it here...

Furr: Yeah I got it right here.

Hefner: Okay go ahead.

Furr: Henry, Tom, Baker 5685.

Hefner: Okay um did you have any uh... besides the one in the gun did you have any mags with you yesterday?

: No, I only had one mag.

21. UCR Clearance Status <input type="checkbox"/> Open <input type="checkbox"/> By Arrest <input type="checkbox"/> Exceptional <input type="checkbox"/> Unfounded		23. Reporting Officer M.L. Hefner	Code 4764	Assignment Homicide	Date 01-27-2017
22. Investigative Status <input type="checkbox"/> Active <input type="checkbox"/> Inactive <input type="checkbox"/> Closed <input type="checkbox"/> Administrative		25. Case Referred To	26. Reviewing Supervisor, Code, Date		

Charlotte Mecklenburg Police Department				COMPLAINT NUMBER 20170126131803	Page # 9 of 57
2. Victim Name Josue Javier Diaz			3. Original Offense / Charge OIS		
4. Location Of Offense 6200 Albemarle Road			5. Arrest Number	6. C.R. Number	
7. Original Report Date 01-26-2017		8. Supplement Date 01-27-2017		9. Correct Incident Classification	
10. Juvenile Case No	11. Multiple Case Clearance No	12. Supplement Confidential Yes	13. Purpose Of Supplement Interview with Detective [REDACTED]		

Hefner: Okay.

[REDACTED] Ten rounds.

Hefner: Okay. Uh did you...were you carrying a secondary issued weapon?

[REDACTED] I did not.

Hefner: Did you have any back up weapons?

[REDACTED] Nope.

Hefner: Uh, the next question says attorney present, I'm putting yes, and Attorney Laughrun. Uh did you take any notes yesterday?

[REDACTED] <Talkover - inaudible>

Hefner: Did you take any notes at all yesterday when all this occurred?

[REDACTED] No.

Hefner: Okay. Alright.

[REDACTED] During the incident, right?

Hefner: Yeah, yeah right after the incident, anything related to this particular case.

[REDACTED] No I did not.

Hefner: I'm just filling out the top of the form, it wasn't done. Okay, alright. Alright you understand um, number one be comfortable alright, it's

21. UCR Clearance Status <input type="checkbox"/> Open <input type="checkbox"/> By Arrest <input type="checkbox"/> Exceptional <input type="checkbox"/> Unfounded		23. Reporting Officer M.L. Hefner	Code Assignment 4764 Homicide	Date 01-27-2017
22. Investigative Status <input type="checkbox"/> Active <input type="checkbox"/> Inactive <input type="checkbox"/> Closed <input type="checkbox"/> Administrative		25. Case Referred To	26. Reviewing Supervisor, Code, Date	

Charlotte Mecklenburg Police Department Supplement Report @				COMPLAINT NUMBER 20170126131803	Page # 10 of 57
2. Victim Name Josue Javier Diaz			3. Original Offense / Charge OIS		
4. Location Of Offense 6200 Albemarle Road			5. Arrest Number	6. C.R. Number	
7. Original Report Date 01-26-2017		8. Supplement Date 01-27-2017		9. Correct Incident Classification	
10. Juvenile Case No	11. Multiple Case Clearance No	12. Supplement Confidential Yes		13. Purpose Of Supplement Interview with Detective [REDACTED]	

just...we're just having a conversation. I have to treat you no different than anybody else, just like a homicide investigation okay. Uh it's not personal, it's just work...

[REDACTED]

I got ya.

Hefner:

...and this is my assignment alright. Uh in fact while I'm saying that I'm gonna go ahead and give you and Mr. Laughrun my card uh so you have my...my contact information. If any reason you need it um...so I think it's best rather than ask you questions you just tell me what happened okay, just... I'm a do my best not to stop you and you go beginning to end for me okay.

[REDACTED]

Okay so where do you want me to start?

Hefner:

Um probably better to tell me where you were coming from when all this started and then go from there.

[REDACTED]

Alright I was coming from Farm Pond, there's some condo's back there and I stopped there because we just finished...we finished a deal and I have to make sure I'm not being followed, so we uh...I made sure I wasn't followed, I stopped there and I waited there for about five, ten minutes...the guy that was with me, I told him, I said I'm good, go do what you gotta do, I went back to my office. Then I was going back to the office to turn the evidence in. So while I'm going over there I'm in the left lane on Albemarle Road headed toward Independence and they hit me, boom...and um I'm actually talking to the other detective that's handling the case with me, I say listen man uh I just got hit, let me get off the phone real quick. So the guy hit me, he pulled to the right and pulls over, but I thought he was pulling over but it's traffic so I get behind him and um...I think we gonna get out so I get out a my car, he looks at me, makes a Uey...boom, so I said

21. UCR Clearance Status <input type="checkbox"/> Open <input type="checkbox"/> By Arrest <input type="checkbox"/> Exceptional <input type="checkbox"/> Unfounded		23. Reporting Officer M.L. Hefner	Code Assignment 4764 Homicide	Date 01-27-2017
22. Investigative Status <input type="checkbox"/> Active <input type="checkbox"/> Inactive <input type="checkbox"/> Closed <input type="checkbox"/> Administrative		25. Case Referred To	26. Reviewing Supervisor, Code, Date	

Charlotte Mecklenburg Police Department Supplement Report @					COMPLAINT NUMBER 20170126131803	Page # 11 of 57
2. Victim Name Josue Javier Diaz			3. Original Offense / Charge OIS			
4. Location Of Offense 6200 Albemarle Road			5. Arrest Number		6. C.R. Number	
7. Original Report Date 01-26-2017		8. Supplement Date 01-27-2017		9. Correct Incident Classification		
10. Juvenile Case No	11. Multiple Case Clearance No	12. Supplement Confidential Yes		13. Purpose Of Supplement Interview with Detective [REDACTED]		

okay so I jumped back in my car, I go and do a Uey with him. At that time I'm reaching... I'm reaching for my radio cause its right there at the door, so I reach for my radio, I change channel, go onto the Eastway channel, and I say listen this guy just hit me uh he trying to get away okay do you have a unit close by that can stop? I believe that's what I said on the radio but don't ... don't quote me on that... <Talkover – inaudible>

Hefner: <Talkover - inaudible>

[REDACTED] ...but something along those lines.

Hefner: Okay.

[REDACTED] So we go straight um we stop at Jenkins, he's like in the left turning lane, I'm right behind him, I call out to dispatch, hey we're right here waiting, he looks like he's gonna make a left turn. The light changes to...to yellow and right... that little space in between yellow and red, boom he takes off so I go ... I go with him and I tell dispatch hey we... we passed the light... whatever. Go all the way to the... to the right lane, right... he brakes, I brake, I bumps into him... boom. Throw it in park, he gets out... I jump out and immediately he jump out, he say's something to me in Spanish like... uh... I'm gonna tell you something... and then that's when I see the silver, looks to me like a four shooter 22... so I told... and he cocks it back, I wasn't sure if it's a single action or double action so it's probably single action so he... he um... he pull it back and as he's raising it, I drew... I engage... I think he got a shot off, I'm not a hundred percent sure, like I was telling him yesterday, cause I see a white smoke coming out, I move, I see... I continue to engage, he collapses, then I know that he's no longer a threat cause I see the gun, so I train my part on the other guy that's in the car, I'm covering him. I think I shot maybe... I'm not sure 5, 6

21. UCR Clearance Status <input type="checkbox"/> Open <input type="checkbox"/> By Arrest <input type="checkbox"/> Exceptional <input type="checkbox"/> Unfounded		23. Reporting Officer M.L. Hefner	Code Assignment 4764 Homicide	Date 01-27-2017
22. Investigative Status <input type="checkbox"/> Active <input type="checkbox"/> Inactive <input type="checkbox"/> Closed <input type="checkbox"/> Administrative		25. Case Referred To	26. Reviewing Supervisor, Code, Date	

Charlotte Mecklenburg Police Department Supplement Report @				COMPLAINT NUMBER 20170126131803	Page # 12 of 57
2. Victim Name Josue Javier Diaz			3. Original Offense / Charge OIS		
4. Location Of Offense 6200 Albemarle Road			5. Arrest Number	6. C.R. Number	
7. Original Report Date 01-26-2017		8. Supplement Date 01-27-2017		9. Correct Incident Classification	
10. Juvenile Case No	11. Multiple Case Clearance No	12. Supplement Confidential Yes		13. Purpose Of Supplement Interview with Detective [REDACTED]	

times... I'm not a hundred percent on that but I... I know I still have... to me it was 6 but I think... in my mind I have four rounds left so I'm covering the guy and I'm telling him, giving him command, hey show me your hands, show me your hands don't move I'm a Police Officer. At the same time I'm calling dispatch and telling hey, you know, this guy ... cause I can see him, um... at my feet, that he's bleeding out, so I call dispatch to start Medic this way but I cannot help him because obviously I have to cover this guy so I'm covering... I call Medic then I call 33 traffic. I put my radio away and the guy keep reaching, he kept like putting his hands down I said listen man don't do that so at that moment I started moving cause from training, if you move it's harder if somebody's... if he has a gun it's harder for him to... if he's looking at you, you stationary, it's easier to pull, point shoot, so I start moving so I start moving this way in front of the car, I see some people in the... Pizza Hut and I say call 911, call 911 as I yell at them, I keep moving onto the other side. I just keep covering him I said let me... show me your hands, put it on the right side because door was open. At that time I looked in peripheral vision when I see uh... a unit coming up... Police unit coming up a... and he's challenging me. He say are you Police? Are you Police? And I say I am Police Officer, I am a Police Officer, and I recognize him as Officer Bumgarner, cause we worked together before. So he comes up, I said there's a gun over there on the other side of the car, boom we take... take the guy out a the car um I assisted him, arrested him, putting handcuffs on him cause I ain't have no handcuffs and that was it. Um everybody else show up and they put me in the back of a Police car and I... I just lay there and I didn't do nothing else.

Hefner: Okay, alright.

[REDACTED] That's, pretty much, the whole story.

21. UCR Clearance Status <input type="checkbox"/> Open <input type="checkbox"/> By Arrest <input type="checkbox"/> Exceptional <input type="checkbox"/> Unfounded		23. Reporting Officer M.L. Hefner	Code 4764	Assignment Homicide	Date 01-27-2017
22. Investigative Status <input type="checkbox"/> Active <input type="checkbox"/> Inactive <input type="checkbox"/> Closed <input type="checkbox"/> Administrative		25. Case Referred To	26. Reviewing Supervisor, Code, Date		

Charlotte Mecklenburg Police Department Supplement Report @				COMPLAINT NUMBER 20170126131803	Page # 13 of 57
2. Victim Name Josue Javier Diaz			3. Original Offense / Charge OIS		
4. Location Of Offense 6200 Albemarle Road			5. Arrest Number	6. C.R. Number	
7. Original Report Date 01-26-2017		8. Supplement Date 01-27-2017		9. Correct Incident Classification	
10. Juvenile Case No	11. Multiple Case Clearance No	12. Supplement Confidential Yes	13. Purpose Of Supplement Interview with Detective [REDACTED]		

Hefner: Okay. So what I'm gonna do is try to start back in the very beginning...

[REDACTED] <Talkover - inaudible>

Hefner: ...and then we'll go through it and I'll ask questions as we go okay.

[REDACTED] Okay.

Hefner: Uh I'm not...I...I promise ya I'm not trying to trick ya I'm just trying to clarify okay.

[REDACTED] Alright.

Hefner: Um...

Furr: It's getting more details, that's all.

Hefner: That's all it is. So you left an operation somewhere on Farm Pond and you said there was a guy...you ...you said it fast but you were talking about a guy being with you, I'm assuming because you said there's no passengers you mean there was someone following you?

[REDACTED] No...yes, it was uh...

Hefner: In another vehicle?

[REDACTED] Yes.

Hefner: Okay uh you told him to do what he had to do and you were headed to the office to turn in evidence?

21. UCR Clearance Status Open <input type="checkbox"/> By Arrest <input type="checkbox"/> Exceptional <input type="checkbox"/> Unfounded <input type="checkbox"/>		23. Reporting Officer M.L. Hefner	Code Assignment 4764 Homicide	Date 01-27-2017
22. Investigative Status <input type="checkbox"/> Active <input type="checkbox"/> Inactive <input type="checkbox"/> Closed <input type="checkbox"/> Administrative <input type="checkbox"/>		25. Case Referred To	26. Reviewing Supervisor, Code, Date	

Charlotte Mecklenburg Police Department Supplement Report ©				COMPLAINT NUMBER 20170126131803	Page # 14 of 57
2. Victim Name Josue Javier Diaz			3. Original Offense / Charge OIS		
4. Location Of Offense 6200 Albemarle Road			5. Arrest Number	6. C.R. Number	
7. Original Report Date 01-26-2017	8. Supplement Date 01-27-2017		9. Correct Incident Classification		
10. Juvenile Case No	11. Multiple Case Clearance No	12. Supplement Confidential Yes	13. Purpose Of Supplement Interview with Detective [REDACTED]		

[REDACTED] That's correct.

Hefner: Okay <Talkover - inaudible>

Laughrun: And that was CMPD, was it not?

[REDACTED] No.

Laughrun: Okay somebody else?

[REDACTED] Yes.

Hefner: Okay. Uh and...and we interviewed a couple people yesterday, uh related to that so um and...and in this case I...I think we're okay but to...I'm comfortable with using some names because it clarifies who we've already interviewed. Uh safe to say that was an ATF agent that was following you at the time?

[REDACTED] No.

Hefner: No? Okay. Well then we won't use a name okay...right now.

[REDACTED] <Talkover - inaudible>

Hefner: So he leaves you so you turn inbound on Albemarle Road at Farm Pond and travelling in bound towards Independence.

[REDACTED] That's correct.

Hefner: Okay. You're in the left lane.

[REDACTED] That's correct.

21. UCR Clearance Status Open <input type="checkbox"/> By Arrest <input type="checkbox"/> Exceptional <input type="checkbox"/> Unfounded <input type="checkbox"/>		23. Reporting Officer M.L. Hefner	Code Assignment 4764 Homicide	Date 01-27-2017
22. Investigative Status Active <input type="checkbox"/> Inactive <input type="checkbox"/> Closed <input type="checkbox"/> Administrative <input type="checkbox"/>		25. Case Referred To	26. Reviewing Supervisor, Code, Date	

Charlotte Mecklenburg Police Department Supplement Report @				COMPLAINT NUMBER 20170126131803	Page # 15 of 57
2. Victim Name Josue Javier Diaz			3. Original Offense / Charge OIS		
4. Location Of Offense 6200 Albemarle Road			5. Arrest Number	6. C.R. Number	
7. Original Report Date 01-26-2017		8. Supplement Date 01-27-2017		9. Correct Incident Classification	
10. Juvenile Case No	11. Multiple Case Clearance No	12. Supplement Confidential Yes	13. Purpose Of Supplement Interview with Detective [REDACTED]		

Hefner: What intersection were you near or where...what was your location when the...when the collision happened?

[REDACTED] I would say about... about 200 meters from Reddman...

Hefner: So...

[REDACTED] ...heading towards um Sharon Amity.

Hefner: Okay alright.

[REDACTED] It's a ch... I know there's a church it used to be a vacant building for a long time, the Sailboat Bay apartments, right next to it is the... used to be daycare but now I think it's some sort of church <Talkover - inaudible>

Hefner: Now I... I know that area, you've already...so you've already gone past where Central Avenue bears off...

[REDACTED] Yes.

Hefner: ...and you're approaching Reddman in the left lane?

[REDACTED] Past Reddman.

Hefner: You're past Reddman?

[REDACTED] Yes.

Hefner: After Reddman, okay.

21. UCR Clearance Status Open <input type="checkbox"/> By Arrest <input type="checkbox"/> Exceptional <input type="checkbox"/> Unfounded <input type="checkbox"/>		23. Reporting Officer M.L. Hefner	Code Assignment 4764 Homicide	Date 01-27-2017
22. Investigative Status <input type="checkbox"/> Active <input type="checkbox"/> Inactive <input type="checkbox"/> Closed <input type="checkbox"/> Administrative <input type="checkbox"/>		25. Case Referred To	26. Reviewing Supervisor, Code, Date	

Charlotte Mecklenburg Police Department Supplement Report @			COMPLAINT NUMBER 20170126131803	Page # 16 of 57
2. Victim Name Josue Javier Diaz		3. Original Offense / Charge OIS		
4. Location Of Offense 6200 Albemarle Road		5. Arrest Number	6. C.R. Number	
7. Original Report Date 01-26-2017	8. Supplement Date 01-27-2017	9. Correct Incident Classification		
10. Juvenile Case No	11. Multiple Case Clearance No	12. Supplement Confidential Yes	13. Purpose Of Supplement Interview with Detective [REDACTED]	

[REDACTED] After Reddman, you're gonna see there's a bank and there's the church and then Sailboat Bay Apartments. It used to be Sailboat Bay, I don't know what they're called right now.

Hefner: Sailboat Bay, yeah I know that...

[REDACTED] Cause I used to work...

Hefner: I know those apartment's, okay.

[REDACTED] ...I used to work um Eastway Division.

Hefner: So it's right there...right near the entrance to where Sailboat Bay is is that what...

[REDACTED] Right before.

Hefner: Right before? Okay.

[REDACTED] Like I said, there's a...there's a church right there on the right with a bunch a flags on it and that's ...right in front of that that's when I got hit, we moved to the right and the other stuff happened.

Hefner: Okay, alright um the collision, tell me about that, where did uh this...where did the...the suspect vehicle strike you?

[REDACTED] Right corner of my ...right back corner of the...the Tahoe.

Hefner: So passenger side, rear of the vehicle?

[REDACTED] Yes sir.

21. UCR Clearance Status Open <input type="checkbox"/> By Arrest <input type="checkbox"/> Exceptional <input type="checkbox"/> Unfounded <input type="checkbox"/>	23. Reporting Officer M.L. Hefner	Code Assignment 4764 Homicide	Date 01-27-2017
22. Investigative Status Active <input type="checkbox"/> Inactive <input type="checkbox"/> Closed <input type="checkbox"/> Administrative <input type="checkbox"/>	25. Case Referred To	26. Reviewing Supervisor, Code, Date	

Charlotte Mecklenburg Police Department Supplement Report ©					COMPLAINT NUMBER 20170126131803	Page # 17 of 57
2. Victim Name Josue Javier Diaz				3. Original Offense / Charge OIS		
4. Location Of Offense 6200 Albemarle Road				5. Arrest Number	6. C.R. Number	
7. Original Report Date 01-26-2017		8. Supplement Date 01-27-2017		9. Correct Incident Classification		
10. Juvenile Case No	11. Multiple Case Clearance No	12. Supplement Confidential Yes	13. Purpose Of Supplement Interview with Detective [REDACTED]			

Hefner: Okay uh when it hit you did you see what part of the suspect vehicle struck you?

[REDACTED] Think the front left.

Hefner: So driver's side headlight area?

[REDACTED] I think he was trying to merge like that and then boom.

Hefner: Okay.

[REDACTED] And then he just kept going <Inaudible>...well go ahead I'll let you <Inaudible>

Hefner: You're alright, no you're fine you keep talking so driver front of the...uh suspect vehicle struck your passenger rear?

[REDACTED] Yeah.

Hefner: Okay. Sorry about the notes I'm trying to clarify things from yesterday, okay. Alright it strikes you um, did it...was it a hard strike, did it bump you in the seat or...

[REDACTED] Just like that...

Hefner: Okay.

[REDACTED] ...bump...bumping the seat.

Hefner: Okay.

[REDACTED] Like I say, I was on the phone like oh damn...I...I got hit.

21. UCR Clearance Status <input type="checkbox"/> Open <input type="checkbox"/> By Arrest <input type="checkbox"/> Exceptional <input type="checkbox"/> Unfounded		23. Reporting Officer M.L. Hefner	Code 4764 Homicide	Assignment 01-27-2017	Date
22. Investigative Status <input type="checkbox"/> Active <input type="checkbox"/> Inactive <input type="checkbox"/> Closed <input type="checkbox"/> Administrative		25. Case Referred To	26. Reviewing Supervisor, Code, Date		

Charlotte Mecklenburg Police Department Supplement Report @					COMPLAINT NUMBER 20170126131803	Page # 18 of 57
2. Victim Name Josue Javier Diaz				3. Original Offense / Charge OIS		
4. Location Of Offense 6200 Albemarle Road				5. Arrest Number		6. C.R. Number
7. Original Report Date 01-26-2017		8. Supplement Date 01-27-2017		9. Correct Incident Classification		
10. Juvenile Case No	11. Multiple Case Clearance No	12. Supplement Confidential Yes		13. Purpose Of Supplement Interview with Detective [REDACTED]		

Hefner: Okay.

[REDACTED] So I...I hung up the phone, said listen man, I'll call you right back, I just got hit so, he merged...he <Inaudible>...so I go right behind him cause I'm assuming that he's gonna get out and look at the vehicle, you know, just like normal people do, but he looks at me and he just make a Uey...

Hefner: Okay.

[REDACTED] ...so, like I said...like I told you before, I went after him and then I call dispatch and say hey, you got a car over here, I called the tag, I called vehicle description and so on...and um there was no...no way to go cause there's traffic, heavy traffic...

Hefner: Okay.

[REDACTED] ...so we just...<Talkover - inaudible>

Hefner: <Talkover - inaudible>...let me stop you so I can clarify, so when they, you bump, he bumps into you...you say he pulls over, did he...does...you're in the left lane does he just pull over to one more lane or...<Talkover - inaudible>

[REDACTED] To the right.

Hefner: All the way to the right?

[REDACTED] Yeah like...like...in the right lane, you know there's two lanes...

Hefner: Okay, there's just two lane...okay.

21. UCR Clearance Status Open <input type="checkbox"/> By Arrest <input type="checkbox"/> Exceptional <input type="checkbox"/> Unfounded <input type="checkbox"/>		23. Reporting Officer M.L. Hefner	Code Assignment 4764 Homicide	Date 01-27-2017
22. Investigative Status <input type="checkbox"/> Active <input type="checkbox"/> Inactive <input type="checkbox"/> Closed <input type="checkbox"/> Administrative <input type="checkbox"/>		25. Case Referred To	26. Reviewing Supervisor, Code, Date	

Charlotte Mecklenburg Police Department Supplement Report @				COMPLAINT NUMBER 20170126131803	Page # 19 of 57
2. Victim Name Josue Javier Diaz			3. Original Offense / Charge OIS		
4. Location Of Offense 6200 Albemarle Road			5. Arrest Number	6. C.R. Number	
7. Original Report Date 01-26-2017	8. Supplement Date 01-27-2017		9. Correct Incident Classification		
10. Juvenile Case No	11. Multiple Case Clearance No	12. Supplement Confidential Yes	13. Purpose Of Supplement Interview with Detective [REDACTED]		

[REDACTED] There's two lanes, there's the...the turning lane...

Hefner: Uh huh.

[REDACTED] ...there's the other two outbound.

Hefner: Okay.

[REDACTED] So he pulls over but I think he just pull there but I'm assuming that he just pulled in there to talk, but there's traffic.

Hefner: <Talkover - inaudible>...did you pull in behind him or had <Talkover - inaudible>

[REDACTED] Yeah I pulled right behind him.

Hefner: And then I think you said you got out of your vehicle.

[REDACTED] Yes.

Hefner: Okay uh did you approach him or did you just go around ...

[REDACTED] No I...I opened my door, I closed the door and I was approaching him like, ya know, yo what's up? Like, ya know, talk like...exchange information, typical thing that...

Hefner: Right.

[REDACTED] ...you do in a typical accident.

Hefner: Sure, sure... Did he ever get out?

21. UCR Clearance Status <input type="checkbox"/> Open <input type="checkbox"/> By Arrest <input type="checkbox"/> Exceptional <input type="checkbox"/> Unfounded		23. Reporting Officer M.L. Hefner	Code Assignment 4764 Homicide	Date 01-27-2017
22. Investigative Status <input type="checkbox"/> Active <input type="checkbox"/> Inactive <input type="checkbox"/> Closed <input type="checkbox"/> Administrative		25. Case Referred To	26. Reviewing Supervisor, Code, Date	

Charlotte Mecklenburg Police Department Supplement Report ©				COMPLAINT NUMBER 20170126131803	Page # 20 of 57
2. Victim Name Josue Javier Diaz			3. Original Offense / Charge OIS		
4. Location Of Offense 6200 Albemarle Road			5. Arrest Number	6. C.R. Number	
7. Original Report Date 01-26-2017	8. Supplement Date 01-27-2017		9. Correct Incident Classification		
10. Juvenile Case No	11. Multiple Case Clearance No	12. Supplement Confidential Yes	13. Purpose Of Supplement Interview with Detective [REDACTED]		

[REDACTED]

No.

Hefner:

Okay did he ever say anything to you?

[REDACTED]

No he just looked at me and made a Uey, boom.

Hefner:

Okay so you're standing in the road when he makes the U-turn?

[REDACTED]

Yeah so I go back in my car cause I <Inaudible>...front left, ya know, past the...the engine...

Hefner:

Uh huh.

[REDACTED]

...so I go back in the car then I make a U-turn, I catch up to him, and then uh, I started calling it in.

Hefner:

And just to clarify a few things, your vehicle has no markings to show that it's a city vehicle?

[REDACTED]

No.

Hefner:

Not tricking ya... <Talkover - inaudible>

[REDACTED]

No I mean...

Hefner:

...I'm just...

[REDACTED]

I thought you was trying to be funny.

Hefner:

No, no, no, no I... it's just clarification.

21. UCR Clearance Status Open <input type="checkbox"/> By Arrest <input type="checkbox"/> Exceptional <input type="checkbox"/> Unfounded <input type="checkbox"/>		23. Reporting Officer M.L. Hefner	Code Assignment 4764 Homicide	Date 01-27-2017
22. Investigative Status Active <input type="checkbox"/> Inactive <input type="checkbox"/> Closed <input type="checkbox"/> Administrative <input type="checkbox"/>		25. Case Referred To	26. Reviewing Supervisor, Code, Date	

Charlotte Mecklenburg Police Department Supplement Report @				COMPLAINT NUMBER 20170126131803	Page # 21 of 57
2. Victim Name Josue Javier Diaz			3. Original Offense / Charge OIS		
4. Location Of Offense 6200 Albemarle Road			5. Arrest Number	6. C.R. Number	
7. Original Report Date 01-26-2017	8. Supplement Date 01-27-2017		9. Correct Incident Classification		
10. Juvenile Case No	11. Multiple Case Clearance No	12. Supplement Confidential Yes	13. Purpose Of Supplement Interview with Detective [REDACTED]		

[REDACTED] Alright.

Hefner: And no emergency equipment on your vehicle, no lights, no siren?

[REDACTED] No lights no nothing.

Hefner: Uh and you had nothing at that point that indicated you were a Police Officer, physically on you no...

[REDACTED] I do not.

Hefner: Okay, and you didn't identify yourself at this point as a Police Officer?

[REDACTED] No.

Hefner: Okay, no reason to.

[REDACTED] No reason... I mean I'm... I'm just following him I'm not engaging him or talking to him...

Hefner: Okay.

[REDACTED] ...in no shape or form.

Hefner: Okay.

[REDACTED] I'm calling the radio having somebody do...

Hefner: I got ya.

[REDACTED] <Talkover - inaudible>

21. UCR Clearance Status Open <input type="checkbox"/> By Arrest <input type="checkbox"/> Exceptional <input type="checkbox"/> Unfounded <input type="checkbox"/>		23. Reporting Officer M.L. Hefner	Code Assignment 4764 Homicide	Date 01-27-2017
22. Investigative Status Active <input type="checkbox"/> Inactive <input type="checkbox"/> Closed <input type="checkbox"/> Administrative <input type="checkbox"/>		25. Case Referred To	26. Reviewing Supervisor, Code, Date	

Charlotte Mecklenburg Police Department Supplement Report ©				COMPLAINT NUMBER 20170126131803	Page # 22 of 57
2. Victim Name Josue Javier Diaz			3. Original Offense / Charge OIS		
4. Location Of Offense 6200 Albemarle Road			5. Arrest Number	6. C.R. Number	
7. Original Report Date 01-26-2017	8. Supplement Date 01-27-2017		9. Correct Incident Classification		
10. Juvenile Case No	11. Multiple Case Clearance No	12. Supplement Confidential Yes	13. Purpose Of Supplement Interview with Detective [REDACTED]		

Hefner: Alright so uh... he throws a U-turn, you follow suit, you throw a U-turn?

[REDACTED] Uh huh.

Hefner: Um it's a pretty good distance from there down to where this... I'd say...

[REDACTED] Bout three quarters of a mile.

Hefner: Right, right and with that traffic it takes a minute if I ...

[REDACTED] Yes sir.

Hefner: <Talkover - inaudible>...time a day. Um so is he driving normal as you're fleeing or is he driving erratic?

[REDACTED] No he's not...no he's not driving erratically... er...erratic or anything, like I say he pulls...we just driving normal, he pulls on the left turning lane to going to Jenkins or... Jenkins I think it is... Jenkins... you got Executive Center on this right so...

Hefner: Okay.

[REDACTED] ...we just sitting there and, like I said, we waited there I would say 45 minutes to a minute then the light changes, like about to change to keep going straight and boom he bolts so I go with him then we go all the way to the right, he slams... he brakes, I keep going, boom... I hit him, boom, get out a the car.

Hefner: And...and...at this point you're in the far right lane, near Pizza Hut?

[REDACTED] Yes.

21. UCR Clearance Status Open <input type="checkbox"/> By Arrest <input type="checkbox"/> Exceptional <input type="checkbox"/> Unfounded <input type="checkbox"/>		23. Reporting Officer M.L. Hefner	Code Assignment 4764 Homicide	Date 01-27-2017
22. Investigative Status Active <input type="checkbox"/> Inactive <input type="checkbox"/> Closed <input type="checkbox"/> Administrative <input type="checkbox"/>		25. Case Referred To	26. Reviewing Supervisor, Code, Date	

Charlotte Mecklenburg Police Department Supplement Report @				COMPLAINT NUMBER 20170126131803	Page # 23 of 57
2. Victim Name Josue Javier Diaz			3. Original Offense / Charge OIS		
4. Location Of Offense 6200 Albemarle Road			5. Arrest Number	6. C.R. Number	
7. Original Report Date 01-26-2017	8. Supplement Date 01-27-2017		9. Correct Incident Classification		
10. Juvenile Case No	11. Multiple Case Clearance No	12. Supplement Confidential Yes	13. Purpose Of Supplement Interview with Detective [REDACTED]		

Hefner: And when you say you ran into him would you say he stopped fast...so fast you couldn't get stopped?

[REDACTED] Well he stopped and I accidentally boom, bump into him.

Hefner: Okay.

[REDACTED] It wasn't like...like a crash, crash, ya know it was just like a possible contact ya know like...

Hefner: I got you.

[REDACTED] ...that kind of thing.

Hefner: I got you.

[REDACTED] You know the car rocks and boom, and ...and then when he get out, I get out.

Hefner: Okay and at any point, at this point, have you seen any marked vehicles or any indic...Police around you at all?

[REDACTED] No.

Hefner: Okay um...did...when you bump did you open your door before he got out of his vehicle or did he get out first?

[REDACTED] No I...I got out...be honest with you I...I don't...I think he was simul...simultaneously kind of thing.

21. UCR Clearance Status Open <input type="checkbox"/> By Arrest <input type="checkbox"/> Exceptional <input type="checkbox"/> Unfounded <input type="checkbox"/>		23. Reporting Officer M.L. Hefner	Code Assignment 4764 Homicide	Date 01-27-2017
22. Investigative Status <input type="checkbox"/> Active <input type="checkbox"/> Inactive <input type="checkbox"/> Closed <input type="checkbox"/> Administrative <input type="checkbox"/>		25. Case Referred To	26. Reviewing Supervisor, Code, Date	

Charlotte Mecklenburg Police Department Supplement Report @				COMPLAINT NUMBER 20170126131803	Page # 24 of 57
2. Victim Name Josue Javier Diaz			3. Original Offense / Charge OIS		
4. Location Of Offense 6200 Albemarle Road			5. Arrest Number	6. C.R. Number	
7. Original Report Date 01-26-2017	8. Supplement Date 01-27-2017		9. Correct Incident Classification		
10. Juvenile Case No	11. Multiple Case Clearance No	12. Supplement Confidential Yes	13. Purpose Of Supplement Interview with Detective [REDACTED]		

Hefner: Right, so you open your door same time he opens <Talkover - inaudible>

[REDACTED] I open my door, he's open it... I throw my... I close my door and uh... cause he gets out, he say I'm a tell you something and then that's when he does that motion...

Hefner: Okay.

[REDACTED] ...like cocking the hammer and then when he start raising the...the...the shooter, that's when I...I go ahead, I already ID'd...I was already in the motion of trying to draw my weapon, and then when I see the motion going towards that he was gonna point it...point it at me, that's when I start engaging...boom, boom, boom. I engage and like I say, I think he got one shot off I'm not a hundred percent because I was telling him I can remember seeing white smoke and he just...he...he seem ...look like he was coming for his gun but I'm not a hundred percent because...

Hefner: Okay.

[REDACTED] ...ya know I...like I said, I think...I think when he got hit that...that angles him, boom then he shoots. And I just...like I say, I...I engage, I stop, and then I'm training on the other guy. That's pretty much it.

Hefner: Alright um and just back up a little bit...

[REDACTED] Okay.

Hefner: ...you get out of the vehicle simultaneously, did you actually put your feet on the pavement and close the door or did you get out and speak

21. UCR Clearance Status <input type="checkbox"/> Open <input type="checkbox"/> By Arrest <input type="checkbox"/> Exceptional <input type="checkbox"/> Unfounded		23. Reporting Officer M.L. Hefner	Code Assignment 4764 Homicide	Date 01-27-2017
22. Investigative Status <input type="checkbox"/> Active <input type="checkbox"/> Inactive <input type="checkbox"/> Closed <input type="checkbox"/> Administrative		25. Case Referred To	26. Reviewing Supervisor, Code, Date	

Charlotte Mecklenburg Police Department Supplement Report @				COMPLAINT NUMBER 20170126131803	Page # 25 of 57
2. Victim Name Josue Javier Diaz			3. Original Offense / Charge OIS		
4. Location Of Offense 6200 Albemarle Road			5. Arrest Number	6. C.R. Number	
7. Original Report Date 01-26-2017	8. Supplement Date 01-27-2017		9. Correct Incident Classification		
10. Juvenile Case No	11. Multiple Case Clearance No	12. Supplement Confidential Yes	13. Purpose Of Supplement Interview with Detective [REDACTED]		

to him with the door open or...where...where were you in relation to your vehicle?

[REDACTED]

I would say that I was like...close to the left front tire.

Hefner:

And let me say it this way...when it's stressful and I've been in stress, we don't always remember okay.

[REDACTED]

Okay.

Hefner:

Here's what I want you to do.

[REDACTED]

But I really trying to remember <Talkover - inaudible>

Hefner:

And...and listen to me, and I...I...I don't...this is your story...

[REDACTED]

Okay.

Hefner:

...if you don't remember it's explainable that you don't remember, we forget things in stress, things don't make sense okay. Uh I can tell you just some of the witnesses yesterday were a mess because they were under stress okay so it's okay that we don't remember things. Uh, don't guess, in other words.

[REDACTED]

Okay.

Hefner:

So if you know, when you open your door what...what do you do, where are you in relation to your vehicle, if you remember?

[REDACTED]

Um like I said...I don't remember exactly where I was.

Hefner:

Okay.

21. UCR Clearance Status <input type="checkbox"/> Open <input type="checkbox"/> By Arrest <input type="checkbox"/> Exceptional <input type="checkbox"/> Unfounded		23. Reporting Officer M.L. Hefner	Code 4764	Assignment Homicide	Date 01-27-2017
22. Investigative Status <input type="checkbox"/> Active <input type="checkbox"/> Inactive <input type="checkbox"/> Closed <input type="checkbox"/> Administrative		25. Case Referred To	26. Reviewing Supervisor, Code, Date		

Charlotte Mecklenburg Police Department Supplement Report @			COMPLAINT NUMBER 20170126131803	Page # 26 of 57
2. Victim Name Josue Javier Diaz		3. Original Offense / Charge OIS		
4. Location Of Offense 6200 Albemarle Road		5. Arrest Number	6. C.R. Number	
7. Original Report Date 01-26-2017	8. Supplement Date 01-27-2017	9. Correct Incident Classification		
10. Juvenile Case No	11. Multiple Case Clearance No	12. Supplement Confidential Yes	13. Purpose Of Supplement Interview with Detective [REDACTED]	

[REDACTED] I'm...I'm making...an educated guess that I was to the front left of the vehicle...

Hefner: Okay.

[REDACTED] ...when I first saw him.

Hefner: Okay.

[REDACTED] When we...when we get out of the car...

Hefner: Okay.

[REDACTED] ...ya know cause I...I walk, ya know, just...

Hefner: Okay.

[REDACTED] ...just like I was gonna tell him hey ya know I'm a cop, just chill, kinda thing...and uh...

Hefner: Did you actually say that, did you ever...

[REDACTED] No, no, no, no, no.

Hefner: ...did you ever identify yourself as Police Officer?

[REDACTED] I didn't have...I didn't...I didn't have a chance, like I say he came out he said that, I saw what he was trying to do and I...and I...I didn't have to time to talk to him at all.

21. UCR Clearance Status <input type="checkbox"/> Open <input type="checkbox"/> By Arrest <input type="checkbox"/> Exceptional <input type="checkbox"/> Unfounded		23. Reporting Officer M.L. Hefner	Code Assignment 4764 Homicide	Date 01-27-2017
22. Investigative Status <input type="checkbox"/> Active <input type="checkbox"/> Inactive <input type="checkbox"/> Closed <input type="checkbox"/> Administrative		25. Case Referred To	26. Reviewing Supervisor, Code, Date	

Charlotte Mecklenburg Police Department Supplement Report @				COMPLAINT NUMBER 20170126131803	Page # 27 of 57
2. Victim Name Josue Javier Diaz			3. Original Offense / Charge OIS		
4. Location Of Offense 6200 Albemarle Road			5. Arrest Number	6. C.R. Number	
7. Original Report Date 01-26-2017	8. Supplement Date 01-27-2017		9. Correct Incident Classification		
10. Juvenile Case No	11. Multiple Case Clearance No	12. Supplement Confidential Yes	13. Purpose Of Supplement Interview with Detective [REDACTED]		

Hefner: Okay and it...and then when I ask you this it's okay to stand up, if you're him can you just show me the motion that he was doing, what was he doing with his hands or where were his hands in relation to his body when he had this gun in his hand?

[REDACTED] Okay so...

Hefner: You can stand up if it helps.

Furr: Yeah.

[REDACTED] So he opens the car, he opens the door...boom, he gets out, he say I'm a show...I'm...I'm gonna tell you something...but he said it in Spanish ya know.

Hefner: Yeah.

[REDACTED] And he does this and then he start going like that and that's when I...go ahead and uh...I shot him, I engage.

Hefner: So is it safe to say when he exited you immediately saw the gun in his hand?

[REDACTED] As soon as he turned I can see like I...like I told him...uh I told him I...I'm not...I'm not a hundred percent but it was a small gun it's like a four shooter like I said, probably a 22 something like that I'm not sure but...and that's when I saw it.

Hefner: Okay.

[REDACTED] I saw it in his hand and um I just engage.

21. UCR Clearance Status <input type="checkbox"/> Open <input type="checkbox"/> By Arrest <input type="checkbox"/> Exceptional <input type="checkbox"/> Unfounded		23. Reporting Officer M.L. Hefner	Code Assignment 4764 Homicide	Date 01-27-2017
22. Investigative Status <input type="checkbox"/> Active <input type="checkbox"/> Inactive <input type="checkbox"/> Closed <input type="checkbox"/> Administrative		25. Case Referred To	26. Reviewing Supervisor, Code, Date	

Charlotte Mecklenburg Police Department Supplement Report @				COMPLAINT NUMBER 20170126131803	Page # 28 of 57
2. Victim Name Josue Javier Diaz			3. Original Offense / Charge OIS		
4. Location Of Offense 6200 Albemarle Road			5. Arrest Number	6. C.R. Number	
7. Original Report Date 01-26-2017		8. Supplement Date 01-27-2017		9. Correct Incident Classification	
10. Juvenile Case No	11. Multiple Case Clearance No	12. Supplement Confidential Yes		13. Purpose Of Supplement Interview with Detective [REDACTED]	

Hefner: Okay and ...and we're gonna talk through this engage, where's your weapon on you, where do you keep it?

[REDACTED] I keep it on my waist, on the right side.

Hefner: Okay so and you touched it and I know that area that's where I like to keep mine...

[REDACTED] Yeah.

Hefner: ...so you're just...just kind a favoring your back...

[REDACTED] Yeah.

Hefner: ...and it's inside the waistband?

[REDACTED] Yes.

Hefner: Okay and um you...you mentioned you were wearing a hoodie so you had to pull up the edge of hoodie to get to it?

[REDACTED] Yes.

Hefner: Okay uh but I'm sure you train this way so ...

[REDACTED] Yes.

Hefner: ...it's something you're comfortable doing?

[REDACTED] Yes sir.

21. UCR Clearance Status <input type="checkbox"/> Open <input type="checkbox"/> By Arrest <input type="checkbox"/> Exceptional <input type="checkbox"/> Unfounded		23. Reporting Officer M.L. Hefner	Code Assignment 4764 Homicide	Date 01-27-2017
22. Investigative Status <input type="checkbox"/> Active <input type="checkbox"/> Inactive <input type="checkbox"/> Closed <input type="checkbox"/> Administrative		25. Case Referred To	26. Reviewing Supervisor, Code, Date	

Charlotte Mecklenburg Police Department Supplement Report @				COMPLAINT NUMBER 20170126131803	Page # 29 of 57
2. Victim Name Josue Javier Diaz			3. Original Offense / Charge OIS		
4. Location Of Offense 6200 Albemarle Road			5. Arrest Number	6. C.R. Number	
7. Original Report Date 01-26-2017	8. Supplement Date 01-27-2017		9. Correct Incident Classification		
10. Juvenile Case No	11. Multiple Case Clearance No	12. Supplement Confidential Yes	13. Purpose Of Supplement Interview with Detective [REDACTED]		

Hefner: You're comfortable getting it out. Um, and there was... Was there any time you give any commands at this point?

[REDACTED] I did not.

Hefner: You did not? And you saw a threat?

[REDACTED] I saw a threat and engage.

Hefner: And you engaged it, okay. Um...you said ...I won't make you say it again, just tell me if I'm wrong, you said you believe it's five or six shots and then you even said I think...believe you said I think it's six?

[REDACTED] Yes.

Hefner: Okay, alright. Uh were they...boom, boom, boom, boom...rapid six shots or is there a pause or...

[REDACTED] No, it was rapid.

Hefner: Rapid?

[REDACTED] Boom, boom, boom, boom, boom...

Hefner: Okay.

[REDACTED] He collapse, stop engaging...reassess and...and train on the other guy.

Hefner: Okay um when he fell did you hear him, was he uh...saying anything, did you hear anything from him?

21. UCR Clearance Status <input type="checkbox"/> Open <input type="checkbox"/> By Arrest <input type="checkbox"/> Exceptional <input type="checkbox"/> Unfounded		23. Reporting Officer M.L. Hefner	Code Assignment 4764 Homicide	Date 01-27-2017
22. Investigative Status <input type="checkbox"/> Active <input type="checkbox"/> Inactive <input type="checkbox"/> Closed <input type="checkbox"/> Administrative		25. Case Referred To	26. Reviewing Supervisor, Code, Date	

Charlotte Mecklenburg Police Department Supplement Report @			COMPLAINT NUMBER 20170126131803	Page # 30 of 57
2. Victim Name Josue Javier Diaz		3. Original Offense / Charge OIS		
4. Location Of Offense 6200 Albemarle Road		5. Arrest Number	6. C.R. Number	
7. Original Report Date 01-26-2017	8. Supplement Date 01-27-2017	9. Correct Incident Classification		
10. Juvenile Case No	11. Multiple Case Clearance No	12. Supplement Confidential Yes	13. Purpose Of Supplement Interview with Detective [REDACTED]	

[REDACTED] He was ...

Hefner: Other than ...

[REDACTED] Yeah.

Hefner: Did he say any words?

[REDACTED] He did not.

Hefner: Okay, alright um...and where do you recall the gun being after he's down?

[REDACTED] He's down on his left side, the gun is by his...by...by...right here on the...on the ...on the road, on the...by his right hand.

Hefner: Okay, alright um...did you ever...you touched the gun at all?

[REDACTED] I...I might a kick it but I'm not a hundred percent. I don't remember but...I think I...ya know, just gave a little tug...

Hefner: Okay.

[REDACTED] Get it away from his hands that's all.

Hefner: Do you ever touch it with your hands in any way?

[REDACTED] I did not.

Hefner: Okay um and then you move to the driver's door, if I understood you correctly...

21. UCR Clearance Status <input type="checkbox"/> Open <input type="checkbox"/> By Arrest <input type="checkbox"/> Exceptional <input type="checkbox"/> Unfounded		23. Reporting Officer M.L. Hefner	Code Assignment 4764 Homicide	Date 01-27-2017
22. Investigative Status <input type="checkbox"/> Active <input type="checkbox"/> Inactive <input type="checkbox"/> Closed <input type="checkbox"/> Administrative		25. Case Referred To	26. Reviewing Supervisor, Code, Date	

Charlotte Mecklenburg Police Department Supplement Report @					COMPLAINT NUMBER 20170126131803	Page # 31 of 57
2. Victim Name Josue Javier Diaz				3. Original Offense / Charge OIS		
4. Location Of Offense 6200 Albemarle Road				5. Arrest Number		6. C.R. Number
7. Original Report Date 01-26-2017		8. Supplement Date 01-27-2017		9. Correct Incident Classification		
10. Juvenile Case No	11. Multiple Case Clearance No	12. Supplement Confidential Yes		13. Purpose Of Supplement Interview with Detective [REDACTED]		

[REDACTED]

Yes.

Hefner:

...you move to the driver's door of his pickup truck?

[REDACTED]

Yes sir.

Hefner:

Okay and was the door still open?

[REDACTED]

I believe at this point...the door was closed.

Hefner:

Was closed? Okay uh...uh do you remember if the window was down?

[REDACTED]

The window was down, yes.

Hefner:

Okay and there was one occupant...

[REDACTED]

Yes sir.

Hefner:

...still in the vehicle? Um...I think you said earlier, Hispanic male occupant?

[REDACTED]

He's a Hispanic male yes.

Hefner:

Okay and...and this entire encounter from the time you'd gotten out of your car until right now you've been speaking Spanish the entire time?

[REDACTED]

No.

Hefner:

English?

[REDACTED]

I was talking to him in English.

21. UCR Clearance Status Open <input type="checkbox"/> By Arrest <input type="checkbox"/> Exceptional <input type="checkbox"/> Unfounded <input type="checkbox"/>		23. Reporting Officer M.L. Hefner	Code Assignment 4764 Homicide	Date 01-27-2017
22. Investigative Status <input type="checkbox"/> Active <input type="checkbox"/> Inactive <input type="checkbox"/> Closed <input type="checkbox"/> Administrative <input type="checkbox"/>		25. Case Referred To	26. Reviewing Supervisor, Code, Date	

Charlotte Mecklenburg Police Department Supplement Report @			COMPLAINT NUMBER 20170126131803	Page # 32 of 57
2. Victim Name Josue Javier Diaz		3. Original Offense / Charge OIS		
4. Location Of Offense 6200 Albemarle Road		5. Arrest Number	6. C.R. Number	
7. Original Report Date 01-26-2017	8. Supplement Date 01-27-2017	9. Correct Incident Classification		
10. Juvenile Case No	11. Multiple Case Clearance No	12. Supplement Confidential Yes	13. Purpose Of Supplement Interview with Detective [REDACTED]	

Hefner: Okay uh and was he responding to you in English?

[REDACTED] Yes.

Hefner: Okay um and...

[REDACTED] You're talking about the guy inside the truck?

Hefner: Sure...

[REDACTED] Yes.

Hefner: Sure.

[REDACTED] When I realized that he speak Spanish then I switch.

Hefner: Okay.

[REDACTED] Cause, ya know, I was try...I was trying to determine because he...I...he kept reaching he kept like putting his hand out I didn't know ...I wanted to make sure I was making it clear to him...

Hefner: Sure.

[REDACTED] ...what I wanted him to do...

Hefner: Sure.

[REDACTED] ...that I wanted to see his hands.

Hefner: Sure.

21. UCR Clearance Status <input type="checkbox"/> Open <input type="checkbox"/> By Arrest <input type="checkbox"/> Exceptional <input type="checkbox"/> Unfounded		23. Reporting Officer M.L. Hefner	Code Assignment 4764 Homicide	Date 01-27-2017
22. Investigative Status <input type="checkbox"/> Active <input type="checkbox"/> Inactive <input type="checkbox"/> Closed <input type="checkbox"/> Administrative		25. Case Referred To	26. Reviewing Supervisor, Code, Date	

Charlotte Mecklenburg Police Department Supplement Report @			COMPLAINT NUMBER 20170126131803	Page # 33 of 57
2. Victim Name Josue Javier Diaz		3. Original Offense / Charge OIS		
4. Location Of Offense 6200 Albemarle Road		5. Arrest Number	6. C.R. Number	
7. Original Report Date 01-26-2017	8. Supplement Date 01-27-2017	9. Correct Incident Classification		
10. Juvenile Case No	11. Multiple Case Clearance No	12. Supplement Confidential Yes	13. Purpose Of Supplement Interview with Detective [REDACTED]	

[REDACTED] And then when he would do it for a couple seconds and then would put 'em down, so that's when I said boom, something's up so I started moving.

Hefner: Right. If you remember and...and this is to clarify some things that we may have gotten in interview yesterday, do you remember how you were standing, your stance...your particular stance as you were ...<Talkover - inaudible>

[REDACTED] I got my radio in one hand and my gun in the other.

Hefner: Okay, okay...

[REDACTED] And I was probably bladed a little bit...

Hefner: Okay what ...what...you're right handed?

[REDACTED] Yes.

Hefner: You shoot right handed? So you're bladed...

[REDACTED] I'm bladed like this because there's a post of the window there...

Hefner: Okay.

[REDACTED] And I'm sitting somewhere close to that ...

Hefner: Okay.

[REDACTED] ...but I'm talking to him and I'm giving him commands to show me your hands, show me your hands, and then I get on...that's when I get

21. UCR Clearance Status <input type="checkbox"/> Open <input type="checkbox"/> By Arrest <input type="checkbox"/> Exceptional <input type="checkbox"/> Unfounded	23. Reporting Officer M.L. Hefner	Code 4764	Assignment Homicide	Date 01-27-2017
22. Investigative Status <input type="checkbox"/> Active <input type="checkbox"/> Inactive <input type="checkbox"/> Closed <input type="checkbox"/> Administrative	25. Case Referred To	26. Reviewing Supervisor, Code, Date		

Charlotte Mecklenburg Police Department Supplement Report @					COMPLAINT NUMBER 20170126131803	Page # 34 of 57
2. Victim Name Josue Javier Diaz				3. Original Offense / Charge OIS		
4. Location Of Offense 6200 Albemarle Road				5. Arrest Number		6. C.R. Number
7. Original Report Date 01-26-2017		8. Supplement Date 01-27-2017		9. Correct Incident Classification		
10. Juvenile Case No	11. Multiple Case Clearance No	12. Supplement Confidential Yes		13. Purpose Of Supplement Interview with Detective [REDACTED]		

on the radio cause I look...I...I can see the other guy he was bl...bleeding profusely.

Hefner: Okay, alright, um and then you move around to the front of the vehicle I believe, I understood you?

[REDACTED] <Inaudible>...I move all the way <Inaudible>...keep giving him commands, I keep covering him, show me your hands, show me your hands because from that angle it's uh...to me, it was more of an advantage to...to uh...for me to see his hands and what was inside the vehicle because from the...from the window you can see it but I don't know what he was...cause I got so many things going because I have to look up for other people I ...I wasn't like...it wasn't like I was doing this number, but I had to look for ...cause I don't know who's coming like...

Hefner: I understand.

[REDACTED] ...a young Police Officer that never seen me before, might engage me <Talkover - inaudible>

Hefner: I understand.

[REDACTED] So I had to look for that, and I remember, like I told you before, I saw that guy walking the random guy that was walking um...on the sidewalk, saw the guy at the Pizza Hut, and I kept walking like that, I even yell at the Pizza Hut guy, call 911, as I was coming around like that and then I stay there, I cover him I say...ya know, I waited for the Police Officer to come up, and then Bumgarner, like I said, showed up he challenge me, I say I'm Police, he came up we assist...we took him out and uh...arrested him.

21. UCR Clearance Status <input type="checkbox"/> Open <input type="checkbox"/> By Arrest <input type="checkbox"/> Exceptional <input type="checkbox"/> Unfounded		23. Reporting Officer M.L. Hefner	Code 4764	Assignment Homicide	Date 01-27-2017
22. Investigative Status <input type="checkbox"/> Active <input type="checkbox"/> Inactive <input type="checkbox"/> Closed <input type="checkbox"/> Administrative		25. Case Referred To	26. Reviewing Supervisor, Code, Date		

Charlotte Mecklenburg Police Department Supplement Report @			COMPLAINT NUMBER 20170126131803	Page # 35 of 57
2. Victim Name Josue Javier Diaz		3. Original Offense / Charge OIS		
4. Location Of Offense 6200 Albemarle Road		5. Arrest Number	6. C.R. Number	
7. Original Report Date 01-26-2017	8. Supplement Date 01-27-2017	9. Correct Incident Classification		
10. Juvenile Case No	11. Multiple Case Clearance No	12. Supplement Confidential Yes	13. Purpose Of Supplement Interview with Detective [REDACTED]	

Hefner: Okay um...

[REDACTED] Secured him.

Hefner: And...and just to clarify one thing, I know you told me you were never able...never had time to identify yourself as a Police Officer...

[REDACTED] That's correct.

Hefner: ...to the decedent, the person who's deceased.

[REDACTED] Yes.

Hefner: But to the passenger were you able to identify yourself as Police?

[REDACTED] Yes I told him Police...

Hefner: Okay.

[REDACTED] Told him I'm a Police Officer, show me your hands.

Hefner: Okay. Um and you're...uh Police identification, was any of that with you at the time?

[REDACTED] No.

Hefner: Okay and was it in the vehicle?

[REDACTED] Yes.

21. UCR Clearance Status <input type="checkbox"/> Open <input type="checkbox"/> By Arrest <input type="checkbox"/> Exceptional <input type="checkbox"/> Unfounded		23. Reporting Officer M.L. Hefner	Code 4764 Homicide	Assignment 01-27-2017	Date
22. Investigative Status <input type="checkbox"/> Active <input type="checkbox"/> Inactive <input type="checkbox"/> Closed <input type="checkbox"/> Administrative		25. Case Referred To	26. Reviewing Supervisor, Code, Date		

Charlotte Mecklenburg Police Department Supplement Report ©					COMPLAINT NUMBER 20170126131803	Page # 36 of 57
2. Victim Name Josue Javier Diaz				3. Original Offense / Charge OIS		
4. Location Of Offense 6200 Albemarle Road				5. Arrest Number		6. C.R. Number
7. Original Report Date 01-26-2017		8. Supplement Date 01-27-2017		9. Correct Incident Classification		
10. Juvenile Case No	11. Multiple Case Clearance No	12. Supplement Confidential Yes		13. Purpose Of Supplement Interview with Detective [REDACTED]		

Hefner: Okay. Um and...and that's...I'm...I'm gonna assume that's a normal thing because of your undercover status. You don't have it on your person.

[REDACTED] Yes I mean I have it ...I have my wallet with my I.D.

Hefner: Right okay.

[REDACTED] And I have the...the other...my badge and my other I.D.'s, I left them right there on the door.

Hefner: Okay, alright um...during this encounter were you injured in any way?

[REDACTED] I was not.

Hefner: Okay. Um and if you're aware do you know if the passenger in the vehicle was injured in any way?

[REDACTED] No.

Hefner: Okay. You don't know or you don't believe he was?

[REDACTED] I don't believe he was...

Hefner: Okay.

[REDACTED] ...we just extract him from the vehicle, put handcuffs on him, and I was done.

Hefner: Okay and then once you handcuffed him and...and I...I believe, I've watched some of the body cam um I believe that you just...you guys sat him there on the sidewalk?

21. UCR Clearance Status <input type="checkbox"/> Open <input type="checkbox"/> By Arrest <input type="checkbox"/> Exceptional <input type="checkbox"/> Unfounded		23. Reporting Officer M.L. Hefner	Code Assignment 4764 Homicide	Date 01-27-2017
22. Investigative Status <input type="checkbox"/> Active <input type="checkbox"/> Inactive <input type="checkbox"/> Closed <input type="checkbox"/> Administrative		25. Case Referred To	26. Reviewing Supervisor, Code, Date	

Charlotte Mecklenburg Police Department Supplement Report @				COMPLAINT NUMBER 20170126131803	Page # 37 of 57
2. Victim Name Josue Javier Diaz			3. Original Offense / Charge OIS		
4. Location Of Offense 6200 Albemarle Road			5. Arrest Number	6. C.R. Number	
7. Original Report Date 01-26-2017	8. Supplement Date 01-27-2017		9. Correct Incident Classification		
10. Juvenile Case No	11. Multiple Case Clearance No	12. Supplement Confidential Yes	13. Purpose Of Supplement Interview with Detective [REDACTED]		

[REDACTED]

Yes.

Hefner:

And then what did you do after that?

[REDACTED]

Um...I can't remember...I think I was...I was just there and then somebody threw me in the back of a Police car.

Hefner:

Okay um do...do you remember sitting beside him or being down close to him there on the sidewalk? If you don't it's okay.

[REDACTED]

I don't.

Hefner:

Okay that's alright, um, it's a stressful situation. Um...at any point did you see...okay, so after you engage the person who's deceased and he's down, uh you mentioned possibly kicking the gun, did you get a better look at the gun at that point, once you were...were there up...up with him?

[REDACTED]

Yes I mean I...I...I know it was a...it was...it was a small gun and it was silver.

Hefner:

Okay.

[REDACTED]

And it was just...laying on the ground. When they ...after we got ...arrested that guy, I remember they...they started getting some traffic up and I said listen, watch the gun cause I didn't wanna like...somebody run it over and leave with...ya know, a truck or something, might get caught up so I told him listen make sure you secure the gun, then somebody went around and...and...I believe some...I don't know who but somebody went around, oh yeah it's right there or whatever.

1. UCR Clearance Status Open <input type="checkbox"/> By Arrest <input type="checkbox"/> Exceptional <input type="checkbox"/> Unfounded <input type="checkbox"/>		23. Reporting Officer M.L. Hefner	Code Assignment 4764 Homicide	Date 01-27-2017
22. Investigative Status <input type="checkbox"/> Active <input type="checkbox"/> Inactive <input type="checkbox"/> Closed <input type="checkbox"/> Administrative <input type="checkbox"/>		25. Case Referred To	26. Reviewing Supervisor, Code, Date	

Charlotte Mecklenburg Police Department Supplement Report @				COMPLAINT NUMBER 20170126131803	Page # 38 of 57
2. Victim Name Josue Javier Diaz			3. Original Offense / Charge OIS		
4. Location Of Offense 6200 Albemarle Road			5. Arrest Number	6. C.R. Number	
7. Original Report Date 01-26-2017	8. Supplement Date 01-27-2017		9. Correct Incident Classification		
10. Juvenile Case No	11. Multiple Case Clearance No	12. Supplement Confidential Yes	13. Purpose Of Supplement Interview with Detective [REDACTED]		

Hefner: Okay um and you said it's silver?

[REDACTED] Yes.

Hefner: And do...do you remember any more specifics about what it looked like?

[REDACTED] I mean it's...I think I say it was like a two shooter...two or four shooter.

Hefner: Okay.

[REDACTED] Uh small gun. I'm assuming it's a 22 I don't know cause I don't...I didn't inspect the gun afterwards but...for the size I'm assuming that that's the caliber it was.

Hefner: Okay um and at any point did you see any other weapon, besides that handgun, that...that revolver or whatever you describe it as...did you see any other weapon besides that gun on the deceased person?

[REDACTED] I did not.

Hefner: Did you see any other weapon on the passenger?

[REDACTED] No.

Hefner: Okay, um if you recall what was the passenger saying to you during this encounter, is he talking back to you?

[REDACTED] He said something uh...along call Medic, ya know, which I already done it, ya know, <Inaudible>...ya know, something along ...along

21. UCR Clearance Status <input type="checkbox"/> Open <input type="checkbox"/> By Arrest <input type="checkbox"/> Exceptional <input type="checkbox"/> Unfounded		23. Reporting Officer M.L. Hefner	Code 4764	Assignment Homicide	Date 01-27-2017
22. Investigative Status <input type="checkbox"/> Active <input type="checkbox"/> Inactive <input type="checkbox"/> Closed <input type="checkbox"/> Administrative		25. Case Referred To	26. Reviewing Supervisor, Code, Date		

Charlotte Mecklenburg Police Department Supplement Report ©			COMPLAINT NUMBER 20170126131803	Page # 39 of 57
2. Victim Name Josue Javier Diaz		3. Original Offense / Charge OIS		
4. Location Of Offense 6200 Albemarle Road		5. Arrest Number	6. C.R. Number	
7. Original Report Date 01-26-2017	8. Supplement Date 01-27-2017	9. Correct Incident Classification		
10. Juvenile Case No	11. Multiple Case Clearance No	12. Supplement Confidential Yes	13. Purpose Of Supplement Interview with Detective [REDACTED]	

those lines about call Medic which already done...done on the radio and I just continued to cover him and that's it.

Hefner: Was there any um...was he confrontation with yall, did he argue with you at all?

[REDACTED] No he...I mean he was...you can tell that he was...I would say a little concerned about what was going on but he wasn't...um...confrontational.

Hefner: Okay.

[REDACTED] I...the only...the only thing, issue I had was that he kept putting his hands down where I couldn't see 'em and that's what...uh...I start doing what I had to do to like, get away from his line of sight.

Hefner: Okay.

[REDACTED] In case he had another weapon, cause I didn't know.

Hefner: I understand, I understand. Um...and coming in here today, you and Mr. Laughrun, prior to coming in here you guys uh alerted us to the fact that there was a picture of what you believed was the gun that you...you had located prior to coming here to see us, is that correct?

[REDACTED] Yes.

Hefner: Okay.

[REDACTED] That's correct.

21. UCR Clearance Status <input type="checkbox"/> Open <input type="checkbox"/> By Arrest <input type="checkbox"/> Exceptional <input type="checkbox"/> Unfounded		23. Reporting Officer M.L. Hefner	Code Assignment 4764 Homicide	Date 01-27-2017
22. Investigative Status <input type="checkbox"/> Active <input type="checkbox"/> Inactive <input type="checkbox"/> Closed <input type="checkbox"/> Administrative		25. Case Referred To	26. Reviewing Supervisor, Code, Date	

Charlotte Mecklenburg Police Department Supplement Report @				COMPLAINT NUMBER 20170126131803	Page # 40 of 57
2. Victim Name Josue Javier Diaz			3. Original Offense / Charge OIS		
4. Location Of Offense 6200 Albemarle Road			5. Arrest Number	6. C.R. Number	
7. Original Report Date 01-26-2017		8. Supplement Date 01-27-2017		9. Correct Incident Classification	
10. Juvenile Case No	11. Multiple Case Clearance No	12. Supplement Confidential Yes		13. Purpose Of Supplement Interview with Detective [REDACTED]	

Hefner: Alright and...and...and um work with me cause I'm a try to get to this point, you located the gun on the decedent's Facebook page, is that correct, or someone did and alerted you to that, you tell me how that came to.

[REDACTED] I couldn't sleep last night so I just wanted to know more about him, ya know, ya know has...has he got a family, whatever... ([REDACTED] gets emotional)...

Hefner: That's...that's okay.

[REDACTED] Um...

Hefner: It's alright.

[REDACTED] So uh I look him up and I saw...went through his pictures and ...and I saw the...the uh...the...the...the gun that I believe was the one that he had...

Hefner: Okay.

[REDACTED] ...in his Facebook page, in his Facebook pictures.

Hefner: Okay and then um...you and I and some other detectives and Mr. Laughrun looked...prior to coming in this room um at...at that gun, you showed us the gun on the Facebook page, is that correct?

[REDACTED] Yes I told ...

Hefner: Okay.

[REDACTED] ...I told you... <Talkover - inaudible>

21. UCR Clearance Status <input type="checkbox"/> Open <input type="checkbox"/> By Arrest <input type="checkbox"/> Exceptional <input type="checkbox"/> Unfounded		23. Reporting Officer M.L. Hefner	Code 4764	Assignment Homicide	Date 01-27-2017
22. Investigative Status <input type="checkbox"/> Active <input type="checkbox"/> Inactive <input type="checkbox"/> Closed <input type="checkbox"/> Administrative		25. Case Referred To	26. Reviewing Supervisor, Code, Date		

Charlotte Mecklenburg Police Department Supplement Report ©				COMPLAINT NUMBER 20170126131803	Page # 41 of 57
2. Victim Name Josue Javier Diaz			3. Original Offense / Charge OIS		
4. Location Of Offense 6200 Albemarle Road			5. Arrest Number	6. C.R. Number	
7. Original Report Date 01-26-2017	8. Supplement Date 01-27-2017		9. Correct Incident Classification		
10. Juvenile Case No	11. Multiple Case Clearance No	12. Supplement Confidential Yes	13. Purpose Of Supplement Interview with Detective [REDACTED]		

Hefner: Okay and...and after ...you ...after we did that, I...the gun, you showed us, I...I printed a picture and I'm...all I'm a do is ask...ask you to look at this picture and you said you believe this is the gun that he possessed...

[REDACTED] <Talkover - inaudible>

Hefner: ...when this encounter happened, is that correct?

[REDACTED] That's correct.

Hefner: Okay and is this the picture that I'm showing you from the...it's a screenshot from Facebook, is this the picture that you showed us?

[REDACTED] Yep that's it.

Hefner: And you're saying this gun looks like the gun he had yesterday?

[REDACTED] Yes.

Hefner: And at the top of this page what's the name here at the top of this page?

[REDACTED] It's...Javier Diaz.

Hefner: Javier Diaz.

[REDACTED] It's the...deceased.

Hefner: Okay, alright and then um...and you...you found this picture overnight last night when you couldn't sleep?

21. UCR Clearance Status <input type="checkbox"/> Open <input type="checkbox"/> By Arrest <input type="checkbox"/> Exceptional <input type="checkbox"/> Unfounded		23. Reporting Officer M.L. Hefner	Code 4764 Homicide	Assignment 01-27-2017	Date
22. Investigative Status <input type="checkbox"/> Active <input type="checkbox"/> Inactive <input type="checkbox"/> Closed <input type="checkbox"/> Administrative		25. Case Referred To	26. Reviewing Supervisor, Code, Date		

Charlotte Mecklenburg Police Department Supplement Report @				COMPLAINT NUMBER 20170126131803	Page # 42 of 57
2. Victim Name Josue Javier Diaz			3. Original Offense / Charge OIS		
4. Location Of Offense 6200 Albemarle Road			5. Arrest Number	6. C.R. Number	
7. Original Report Date 01-26-2017	8. Supplement Date 01-27-2017		9. Correct Incident Classification		
10. Juvenile Case No	11. Multiple Case Clearance No	12. Supplement Confidential Yes	13. Purpose Of Supplement Interview with Detective [REDACTED]		

[REDACTED]

Yes.

Hefner:

Okay and...and I printed out another picture this is...so what I'm ...this first photograph is a picture of the gun of course but then what I did is screen shot his actual Facebook profile page to show what the page looks like, is this the...the page...the page...

[REDACTED]

Yes, that's the page I went to.

Hefner:

<Talkover - inaudible>

[REDACTED]

<Talkover - inaudible>

Hefner:

Okay, alright, um and did you see anything else in...as you peruse through these photo's and I...I don't know how long you spent on it that...that maybe alerted you or made you think about things from yesterday, clothing or anything in particular that you recalled from yesterday?

[REDACTED]

I did not...all I noticed like...like I said <Inaudible>...see him doing gang signs and I'm familiar with those so I know he's uh...ya know he obviously right there he says Sureno Trece...which is a local gang...

Hefner:

Okay.

[REDACTED]

SUR 13, so I...I was like oh he...so he's...he's a gang member.

Hefner:

Sure.

[REDACTED]

Um <Talkover - inaudible>

21. UCR Clearance Status <input type="checkbox"/> Open <input type="checkbox"/> By Arrest <input type="checkbox"/> Exceptional <input type="checkbox"/> Unfounded		23. Reporting Officer M.L. Hefner	Code 4764 Homicide	Assignment 01-27-2017	Date
22. Investigative Status <input type="checkbox"/> Active <input type="checkbox"/> Inactive <input type="checkbox"/> Closed <input type="checkbox"/> Administrative		25. Case Referred To	26. Reviewing Supervisor, Code, Date		

Charlotte Mecklenburg Police Department Supplement Report ©				COMPLAINT NUMBER 20170126131803	Page # 43 of 57
2. Victim Name Josue Javier Diaz			3. Original Offense / Charge OIS		
4. Location Of Offense 6200 Albemarle Road			5. Arrest Number	6. C.R. Number	
7. Original Report Date 01-26-2017		8. Supplement Date 01-27-2017		9. Correct Incident Classification	
10. Juvenile Case No	11. Multiple Case Clearance No	12. Supplement Confidential Yes		13. Purpose Of Supplement Interview with Detective [REDACTED]	

Laughrun: But you didn't know any of that at the time.

[REDACTED] I didn't know none a that.

Hefner: You didn't know any of that, you ...you're just saying you've learned this through looking through the Facebook page?

[REDACTED] Yes.

Hefner: Okay um and...and...and while we're at this subject in...in case I...I'm gonna take...I have to take this photo with me out of here but I want you to know that this is the same photo that I showed you during this interview if you...

[REDACTED] Yeah.

Hefner: ...and me...and Mr. Laughrun ever meet again, if you will on...just on the...the edge of these pages if you'll just sign here and here that way when you see it you'll know it's the same photo we looked at.

Laughrun: <Inaudible>...while you're doing that, you actually showed me those when you came to my office this afternoon did you not?

[REDACTED] Yes we did.

Laughrun: <Talkover - inaudible>

Hefner: <Inaudible>...if you would, just write the date on it <Inaudible>... 1... 1/27/17 and I've got 1641.

Laughrun: It's was roughly 2:30, quarter to 3.

21. UCR Clearance Status <input type="checkbox"/> Open <input type="checkbox"/> By Arrest <input type="checkbox"/> Exceptional <input type="checkbox"/> Unfounded		23. Reporting Officer M.L. Hefner	Code 4764	Assignment Homicide	Date 01-27-2017
22. Investigative Status <input type="checkbox"/> Active <input type="checkbox"/> Inactive <input type="checkbox"/> Closed <input type="checkbox"/> Administrative		25. Case Referred To	26. Reviewing Supervisor, Code, Date		

Charlotte Mecklenburg Police Department Supplement Report @				COMPLAINT NUMBER 20170126131803	Page # 44 of 57
2. Victim Name Josue Javier Diaz			3. Original Offense / Charge OIS		
4. Location Of Offense 6200 Albemarle Road			5. Arrest Number	6. C.R. Number	
7. Original Report Date 01-26-2017		8. Supplement Date 01-27-2017		9. Correct Incident Classification	
10. Juvenile Case No	11. Multiple Case Clearance No	12. Supplement Confidential Yes		13. Purpose Of Supplement Interview with Detective [REDACTED]	

[REDACTED]

Said 1641?

Hefner:

1641 yes sir. Alright. And um...I...I...I just...before I turn it over to Sergeant Furr I wanna ask one question, one other question, at the time that you...your words, engaged the deceased person, do you feel you had any other option at that point than to engage him?

[REDACTED]

I did not. He was either gonna shoot me or I was gonna shoot him.

Hefner:

Okay.

[REDACTED]

So, like I say, I was just...I...I just defended myself. I mean, there's no other way to put it.

Hefner:

Okay.

[REDACTED]

I mean it's...it's unfortunate but, and I feel bad for the whole situation, it's kind a messed up.

Hefner:

Sure.

[REDACTED]

But um, ya know, it's...<Inaudible>

Hefner:

<Talkover - inaudible>

[REDACTED]

...part of the job I guess.

Hefner:

Okay um I...I missed this part uh I should've asked you, do you recall what he was wearing at the time?

[REDACTED]

Think it was a...some sort of white shirt and uh jeans. I don't remember.

21. UCR Clearance Status <input type="checkbox"/> Open <input type="checkbox"/> By Arrest <input type="checkbox"/> Exceptional <input type="checkbox"/> Unfounded		23. Reporting Officer M.L. Hefner	Code Assignment 4764 Homicide	Date 01-27-2017
22. Investigative Status <input type="checkbox"/> Active <input type="checkbox"/> Inactive <input type="checkbox"/> Closed <input type="checkbox"/> Administrative		25. Case Referred To	26. Reviewing Supervisor, Code, Date	

Charlotte Mecklenburg Police Department Supplement Report @				COMPLAINT NUMBER 20170126131803	Page # 45 of 57
2. Victim Name Josue Javier Diaz			3. Original Offense / Charge OIS		
4. Location Of Offense 6200 Albemarle Road			5. Arrest Number	6. C.R. Number	
7. Original Report Date 01-26-2017	8. Supplement Date 01-27-2017		9. Correct Incident Classification		
10. Juvenile Case No	11. Multiple Case Clearance No	12. Supplement Confidential Yes	13. Purpose Of Supplement Interview with Detective [REDACTED]		

Hefner: Okay.

Furr: Uh going back to the question that Detective Hefner just asked you about uh whether or not you had any other options and um...uh going along with your response to that uh what was going through your mind at that time um...would you say that you were in fear for your life?

[REDACTED] I was.

Furr: Uh huh.

[REDACTED] If somebody pointed a gun at you, you know...unless you know you used to that kind of stuff but I mean I...I...he pointed the gun at me I wasn't... Obviously he...he...he was trying to shoot me, so that's...why I did what I had to do, you know, not... none of us go out here, ya know, I'm gonna shoot somebody today ya know, it's just...ya know...it's unfortunate like I said.

Furr: Right.

[REDACTED] But I...I felt like I didn't have no other option.

Furr: Okay and...and...and we've had conversations about uh departmental issued equipment and we covered it earlier today or in this interview with the OIS form, the standardized form where Detective Hefner was asking you questions about any other equipment on your person and you advised, you stated, that there were no other pieces of issued equipment on you, you had no additional weapons, you had no additional ammunition. Uh you had no other um... ways of defending yourself.

21. UCR Clearance Status <input type="checkbox"/> Open <input type="checkbox"/> By Arrest <input type="checkbox"/> Exceptional <input type="checkbox"/> Unfounded		23. Reporting Officer M.L. Hefner	Code 4764	Assignment Homicide	Date 01-27-2017
22. Investigative Status <input type="checkbox"/> Active <input type="checkbox"/> Inactive <input type="checkbox"/> Closed <input type="checkbox"/> Administrative		25. Case Referred To	26. Reviewing Supervisor, Code, Date		

Charlotte Mecklenburg Police Department Supplement Report @				COMPLAINT NUMBER 20170126131803	Page # 46 of 57
2. Victim Name Josue Javier Diaz			3. Original Offense / Charge OIS		
4. Location Of Offense 6200 Albemarle Road			5. Arrest Number	6. C.R. Number	
7. Original Report Date 01-26-2017	8. Supplement Date 01-27-2017		9. Correct Incident Classification		
10. Juvenile Case No	11. Multiple Case Clearance No	12. Supplement Confidential Yes	13. Purpose Of Supplement Interview with Detective [REDACTED]		

[REDACTED] I had my radio and my gun.

Furr: Right...right. Um going back to that...that you...you referred to it a couple of times is that...that engagement on Diaz when you saw that he was armed um...and I know that you've been through this a couple a times, but that is obviously the most important part of all of this. Can you just go through, again, step by step and explain to us, state to us um...how he uh produced that weapon and you described it very clearly when you first saw it um based on what you said there was no mistaking that it was a...a hand gun.

[REDACTED] Yes sir.

Furr: Okay you described it to a tee. Um just, if you can remember, tell us uh what hand he had the weapon in, and what movement he made, and to what uh height he raised the weapon when you engaged, if you could just clearly go through that.

[REDACTED] Well he gets out of the car and he's like...he said in Spanish its like...it's like <Spanish>...which means like...he say I'm...I'm gonna tell you something...

Furr: Uh huh.

[REDACTED] ...and then he ...with his left hand I see like...well I'm assuming, like I said before, that it's a revolver and he was cocking the hammer back.

Furr: Right.

[REDACTED] But it was a single action, which you have to do that. So he cocks it back, he start raising it and that's when I took action.

24. UCR Clearance Status <input type="checkbox"/> Open <input type="checkbox"/> By Arrest <input type="checkbox"/> Exceptional <input type="checkbox"/> Unfounded		23. Reporting Officer M.L. Hefner	Code Assignment 4764 Homicide	Date 01-27-2017
22. Investigative Status <input type="checkbox"/> Active <input type="checkbox"/> Inactive <input type="checkbox"/> Closed <input type="checkbox"/> Administrative		25. Case Referred To	26. Reviewing Supervisor, Code, Date	

Charlotte Mecklenburg Police Department Supplement Report @			COMPLAINT NUMBER 20170126131803	Page # 47 of 57
2. Victim Name Josue Javier Diaz		3. Original Offense / Charge OIS		
4. Location Of Offense 6200 Albemarle Road		5. Arrest Number	6. C.R. Number	
7. Original Report Date 01-26-2017	8. Supplement Date 01-27-2017	9. Correct Incident Classification		
10. Juvenile Case No	11. Multiple Case Clearance No	12. Supplement Confidential Yes	13. Purpose Of Supplement Interview with Detective [REDACTED]	

Furr: Okay, okay he started raising it and at the point that you saw him raise it you drew your weapon? Is that correct?

[REDACTED] That's correct.

Furr: Okay.

[REDACTED] I drew and engaged.

Furr: Uh huh.

[REDACTED] And it was...there was no words or nothing, I drew...engage, that's it.

Furr: And just to clarify about the shots that you fired, do you believe that you fired all of them right then and there or did you move to a ...<Inaudible>... a second location and fire additional shots? Let's just go through that one more time just so we're completely clear on that.

[REDACTED] I did not...I engage boom, boom, boom, boom, boom and then I close the distance...

Furr: Uh huh.

[REDACTED] ...I saw...I see him collapse...

Furr: Right.

[REDACTED] ...so I close the distance and, like I say, once I deci... once I determined that ...I reassessed that he's no longer a threat. I focus on the other guy that was in the car.

Furr: Alright. Alright.

21. UCR Clearance Status <input type="checkbox"/> Open <input type="checkbox"/> By Arrest <input type="checkbox"/> Exceptional <input type="checkbox"/> Unfounded		23. Reporting Officer M.L. Hefner	Code 4764 Homicide	Assignment 01-27-2017	Date
22. Investigative Status <input type="checkbox"/> Active <input type="checkbox"/> Inactive <input type="checkbox"/> Closed <input type="checkbox"/> Administrative		25. Case Referred To	26. Reviewing Supervisor, Code, Date		

Charlotte Mecklenburg Police Department Supplement Report ©			COMPLAINT NUMBER 20170126131803	Page # 48 of 57
2. Victim Name Josue Javier Diaz		3. Original Offense / Charge OIS		
4. Location Of Offense 6200 Albemarle Road		5. Arrest Number	6. C.R. Number	
7. Original Report Date 01-26-2017	8. Supplement Date 01-27-2017	9. Correct Incident Classification		
10. Juvenile Case No	11. Multiple Case Clearance No	12. Supplement Confidential Yes	13. Purpose Of Supplement Interview with Detective [REDACTED]	

Hefner: Um you said something earlier, I meant to go back to it, I thought I heard you say you saw smoke, what you thought was smoke...

[REDACTED] Yes.

Hefner: ...at one point, clarify that for me, what...what do you mean? Do you...

[REDACTED] As I was... <Inaudible>... I was engaging, you know he was raising the gun, I start engage, like I say I think... now I'm not a hundred percent sure, but I think he got one shot off...

Hefner: Okay.

[REDACTED] ...because I remember seeing the white smoke coming up from his hand.

Hefner: Okay.

[REDACTED] And he's... <Inaudible> he's going like that like sideways like that. I see the smoke come up but I... I continue to engage until I knew that... ya know, that he... the threat was no longer... he was no longer a threat.

Hefner: Okay, alright uh... again, another question I missed earlier I should've asked um your own magazine, if... if you remember, what's the capacity on the gun <Talkover - inaudible>

[REDACTED] It's a ten rounder, so I got ten and one, I got one in the chamber and ten in the magazine.

4. UCR Clearance Status Open <input type="checkbox"/> By Arrest <input type="checkbox"/> Exceptional <input type="checkbox"/> Unfounded <input type="checkbox"/>		23. Reporting Officer M.L. Hefner	Code Assignment 4764 Homicide	Date 01-27-2017
22. Investigative Status <input type="checkbox"/> Active <input type="checkbox"/> Inactive <input type="checkbox"/> Closed <input type="checkbox"/> Administrative <input type="checkbox"/>		25. Case Referred To	26. Reviewing Supervisor, Code, Date	

Charlotte Mecklenburg Police Department Supplement Report ©				COMPLAINT NUMBER 20170126131803	Page # 49 of 57
2. Victim Name Josue Javier Diaz			3. Original Offense / Charge OIS		
4. Location Of Offense 6200 Albemarle Road			5. Arrest Number	6. C.R. Number	
7. Original Report Date 01-26-2017		8. Supplement Date 01-27-2017		9. Correct Incident Classification	
10. Juvenile Case No	11. Multiple Case Clearance No	12. Supplement Confidential Yes		13. Purpose Of Supplement Interview with Detective [REDACTED]	

Hefner: Okay and you carry your magazine fully loaded with ten?

[REDACTED] Yes sir.

Hefner: Okay so you would've had ten rou...you would've had ten rounds in the mag and one in the chamber when the...when this started?

[REDACTED] Yes.

Hefner: Okay, alright.

Furr: Um Detective [REDACTED] uh we've clearly identified who the deceased is in this case, it's Mr. Diaz, um but we referred to earlier that you had uh performed a Vice operation before this incident took place. Um...and we didn't talk about it in detail uh, was Mr. Diaz in any way involved in this Vice operation?

[REDACTED] No he did not.

Furr: Okay had you ever seen Mr. Diaz before the hit and run incident?

[REDACTED] Nope never seen him before.

Furr: So you had no interactions with Mr. Diaz or his passenger in any way prior to that initial hit and run where you got out and ...of your vehicle and you saw them in that vehicle proceed to take a U-turn and flee from the hit and run scene, is that correct?

[REDACTED] That's correct.

21. UCR Clearance Status <input type="checkbox"/> Open <input type="checkbox"/> By Arrest <input type="checkbox"/> Exceptional <input type="checkbox"/> Unfounded		23. Reporting Officer M.L. Hefner	Code Assignment 4764 Homicide	Date 01-27-2017
22. Investigative Status <input type="checkbox"/> Active <input type="checkbox"/> Inactive <input type="checkbox"/> Closed <input type="checkbox"/> Administrative		25. Case Referred To	26. Reviewing Supervisor, Code, Date	

Charlotte Mecklenburg Police Department Supplement Report ©				COMPLAINT NUMBER 20170126131803	Page # 50 of 57
2. Victim Name Josue Javier Diaz			3. Original Offense / Charge OIS		
4. Location Of Offense 6200 Albemarle Road			5. Arrest Number	6. C.R. Number	
7. Original Report Date 01-26-2017	8. Supplement Date 01-27-2017		9. Correct Incident Classification		
10. Juvenile Case No	11. Multiple Case Clearance No	12. Supplement Confidential Yes	13. Purpose Of Supplement Interview with Detective [REDACTED]		

Furr: Okay. Alright if you can remember, to the best of your memory, uh what was traffic like in front of um...the Nissan pickup truck that you were stopped directly behind? What was traffic like?

[REDACTED] Where?

Furr: Uh, on Albemarle Road.

[REDACTED] Outbound or inbound?

Furr: Outbound.

[REDACTED] Like going towards Independence?

Furr: No.

Hefner: No where the...where the shooting happened.

<Talkover - inaudible>

[REDACTED] It was heavy traffic.

Furr: It was heavy traffic?

[REDACTED] Yes.

Furr: Okay. And I know that you were completely focused on Mr. Diaz, especially after he became a threat. Um do you have any idea what traffic was like behind you or what was going on behind you?

[REDACTED] Uh...not at that time, like I say, I focus on him, engage. When I have a chance to reassess, that's when I notice, uh the traffic was backed up

21. UCR Clearance Status <input type="checkbox"/> Open <input type="checkbox"/> By Arrest <input type="checkbox"/> Exceptional <input type="checkbox"/> Unfounded		23. Reporting Officer M.L. Hefner	Code Assignment 4764 Homicide	Date 01-27-2017
22. Investigative Status <input type="checkbox"/> Active <input type="checkbox"/> Inactive <input type="checkbox"/> Closed <input type="checkbox"/> Administrative		25. Case Referred To	26. Reviewing Supervisor, Code, Date	

Charlotte Mecklenburg Police Department Supplement Report @				COMPLAINT NUMBER 20170126131803	Page # 51 of 57
2. Victim Name Josue Javier Diaz			3. Original Offense / Charge OIS		
4. Location Of Offense 6200 Albemarle Road			5. Arrest Number	6. C.R. Number	
7. Original Report Date 01-26-2017		8. Supplement Date 01-27-2017		9. Correct Incident Classification	
10. Juvenile Case No	11. Multiple Case Clearance No	12. Supplement Confidential Yes		13. Purpose Of Supplement Interview with Detective [REDACTED]	

like way back, and uh ...and that's when I started looking for, you know... reassess our, ya know, you...you come off a that tunnel vision thing and you reassess and then, I'm looking for other threats, I'm looking at the guy that's right here but I...I had to be conscious of, like I said, a young officer coming and he didn't know me or... a civilian, ya know, CCW carrier...or something that ...that might feel that like I was a threat to somebody else and engage me.

Laughrun: Cause the way you were dressed?

[REDACTED] Cause the way I was dressed, I had nothing that...that say's Police on it.

Furr: Okay what was the distance between you and Mr. Diaz when you engaged?

[REDACTED] I would say five...eight meters.

Furr: Okay.

[REDACTED] Was really close <Inaudible>...I mean...literally like the cars are touching and he gets out, I get out so it's probably five meters...

Furr: Okay.

[REDACTED] ...five, ten meters ya know.

Furr: If you were to...and I know it was unclear because we covered that that you may have been a little unclear as to where you were standing exactly when you engaged, um so I won't have you go through that again, but can you remember where he was standing when you engaged?

21. UCR Clearance Status <input type="checkbox"/> Open <input type="checkbox"/> By Arrest <input type="checkbox"/> Exceptional <input type="checkbox"/> Unfounded		23. Reporting Officer M.L. Hefner	Code Assignment 4764 Homicide	Date 01-27-2017
22. Investigative Status <input type="checkbox"/> Active <input type="checkbox"/> Inactive <input type="checkbox"/> Closed <input type="checkbox"/> Administrative		25. Case Referred To	26. Reviewing Supervisor, Code, Date	

Charlotte Mecklenburg Police Department Supplement Report @				COMPLAINT NUMBER 20170126131803	Page # 52 of 57
2. Victim Name Josue Javier Diaz			3. Original Offense / Charge OIS		
4. Location Of Offense 6200 Albemarle Road			5. Arrest Number	6. C.R. Number	
7. Original Report Date 01-26-2017		8. Supplement Date 01-27-2017		9. Correct Incident Classification	
10. Juvenile Case No	11. Multiple Case Clearance No	12. Supplement Confidential Yes		13. Purpose Of Supplement Interview with Detective [REDACTED]	

[REDACTED]

Was standing by the driver's side door.

Furr:

Okay so he was at the door of his pickup truck that he was operating...

[REDACTED]

Yeah like the doors closed and he's like this is...this is the seam of the door right here, he's like right there.

Furr:

Okay do you remember your back drop at that point?

[REDACTED]

There was uh... Alright I was just...I got ...it's difficult to tell, but I... I'm assuming it has to be traffic, cause you know because we in traffic.

Furr:

Right.

[REDACTED]

Yeah but I don't...I don't...remember exactly that. Like I say I see the gun and I just...my eyes just like...zoom on it then the rest is just, ya know...just training.

Furr:

Uh huh.

[REDACTED]

But uh...(sighs)

Laughrun:

May I?

Furr:

Uh huh.

Laughrun:

Detective [REDACTED] let me ask you, Detective Hefner asked you...he...I believe he said you assumed what type of gun it was? It was no question in your mind it was a firearm was it?

1. UCR Clearance Status <input type="checkbox"/> Open <input type="checkbox"/> By Arrest <input type="checkbox"/> Exceptional <input type="checkbox"/> Unfounded		23. Reporting Officer M.L. Hefner	Code 4764 Homicide	Assignment 01-27-2017	Date
22. Investigative Status <input type="checkbox"/> Active <input type="checkbox"/> Inactive <input type="checkbox"/> Closed <input type="checkbox"/> Administrative		25. Case Referred To	26. Reviewing Supervisor, Code, Date		

Charlotte Mecklenburg Police Department Supplement Report ©					COMPLAINT NUMBER 20170126131803	Page # 53 of 57
2. Victim Name Josue Javier Diaz			3. Original Offense / Charge OIS			
4. Location Of Offense 6200 Albemarle Road			5. Arrest Number		6. C.R. Number	
7. Original Report Date 01-26-2017		8. Supplement Date 01-27-2017		9. Correct Incident Classification		
10. Juvenile Case No	11. Multiple Case Clearance No	12. Supplement Confidential Yes		13. Purpose Of Supplement Interview with Detective [REDACTED]		

[REDACTED] There was no question, yeah, there was no question <Talkover - inaudible>

Laughrun: As to what type though, you had no idea <Talkover - inaudible>

[REDACTED] Uh what type I don't know, I mean I...I... explained to you I...I described I think it was like a...four shot or a two shot...<Inaudible> a .22, but I'm not a hundred percent because I didn't get a time to inspect it, had chance to inspect it.

Laughrun: And when you got out what type of tone of voice was he using?

[REDACTED] He was like, you know, like... kind a aggressive you know, like you get out a the car and say hey I'm a tell you something, ya know, that kind of thing.

Laughrun: He said that in Spanish...

[REDACTED] Yes.

Laughrun: ...but you speak fluent Spanish because you were born in Puerto Rico, correct?

[REDACTED] That's my native speak...my native language yes.

Laughrun: Okay. Uh Detective Hefner also asked you how many shots you fired, you have not been through a bullet count.

[REDACTED] I have not.

21. UCR Clearance Status <input type="checkbox"/> Open <input type="checkbox"/> By Arrest <input type="checkbox"/> Exceptional <input type="checkbox"/> Unfounded		23. Reporting Officer M.L. Hefner		Code 4764	Assignment Homicide	Date 01-27-2017
22. Investigative Status <input type="checkbox"/> Active <input type="checkbox"/> Inactive <input type="checkbox"/> Closed <input type="checkbox"/> Administrative		25. Case Referred To		26. Reviewing Supervisor, Code, Date		

Charlotte Mecklenburg Police Department Supplement Report ©				COMPLAINT NUMBER 20170126131803	Page # 54 of 57
2. Victim Name Josue Javier Diaz			3. Original Offense / Charge OIS		
4. Location Of Offense 6200 Albemarle Road			5. Arrest Number	6. C.R. Number	
7. Original Report Date 01-26-2017		8. Supplement Date 01-27-2017		9. Correct Incident Classification	
10. Juvenile Case No	11. Multiple Case Clearance No	12. Supplement Confidential Yes	13. Purpose Of Supplement Interview with Detective [REDACTED]		

Laughrun: Okay. Alright and the last time question I wanna ask you is when you saw the weapon what went through your mind?

[REDACTED] That he was gonna shoot me.

Laughrun: And then he pointed at you?

[REDACTED] And... yeah.

Laughrun: Okay one other thing, you had no taser, no asp baton, nothing?

[REDACTED] Nah I don't have nothing <Inaudible>

Laughrun: And you had no chance to use any verbal commands did you?

[REDACTED] No because it happened like...it happened like really fast.

Laughrun: Okay. Thank you guys, thank you.

Furr: I've got another question that just came to mind, um and this is just another clarifying question to just...um...try to uh understand your mindset in all of this, um...had anything uh happened or did Mr. Diaz or his passenger do anything at any point from the initial hit and run until when the engagement occurred that would lead you to believe that this was going to be some sort of violent confrontation?

[REDACTED] No.

Furr: Okay.

* UCR Clearance Status Open <input type="checkbox"/> By Arrest <input type="checkbox"/> Exceptional <input type="checkbox"/> Unfounded <input type="checkbox"/>		23. Reporting Officer M.L. Hefner	Code Assignment 4764 Homicide	Date 01-27-2017
22. Investigative Status <input type="checkbox"/> Active <input type="checkbox"/> Inactive <input type="checkbox"/> Closed <input type="checkbox"/> Administrative <input type="checkbox"/>		25. Case Referred To	26. Reviewing Supervisor, Code, Date	

Charlotte Mecklenburg Police Department Supplement Report ©				COMPLAINT NUMBER 20170126131803	Page # 55 of 57
2. Victim Name Josue Javier Diaz			3. Original Offense / Charge OIS		
4. Location Of Offense 6200 Albemarle Road			5. Arrest Number	6. C.R. Number	
7. Original Report Date 01-26-2017	8. Supplement Date 01-27-2017		9. Correct Incident Classification		
10. Juvenile Case No	11. Multiple Case Clearance No	12. Supplement Confidential Yes	13. Purpose Of Supplement Interview with Detective [REDACTED]		

[REDACTED] There was no indication what so ever, I was under the... I'll be honest with you, I ... he was... I would think that he was just trying to get away, maybe he didn't have a license or anything...

Furr: Uh huh.

[REDACTED] ...but, you know, we don't... we're not gonna arrest him for that but, you know, we responsible for those vehicles, with our city vehicle.

Furr: Absolutely.

[REDACTED] And I didn't have a chance to inspect my vehicle. Ya know if he would a just... stop and talk there was... it was... really no damage to the ...to the city vehicle so it's... it's so senseless ya know. If he would a stopped and we talk about it it would be over with, ya know.

Furr: Right.

[REDACTED] But I don't know ... it's just an unfortunate situation like I said.

Furr: We're good.

Laughrun: Okay <Talkover - inaudible>

Hefner: Um one other thing, after the ...the incident occurred, after you were put in the back of a Police car um, what happened to your firearm what... where did it get moved to or... ?

[REDACTED] I ... I told them I had my firearm with me and uh they say where is it at? I... I removed it from... I put it back in my holster, I took my holster out, it's a leather holster, and I put it next to me and its... I was there for a little bit and then eventually I left it on the bottom, the floor of

21. UCR Clearance Status <input type="checkbox"/> Open <input type="checkbox"/> By Arrest <input type="checkbox"/> Exceptional <input type="checkbox"/> Unfounded		23. Reporting Officer M.L. Hefner	Code 4764 Homicide	Assignment 01-27-2017	Date
22. Investigative Status <input type="checkbox"/> Active <input type="checkbox"/> Inactive <input type="checkbox"/> Closed <input type="checkbox"/> Administrative		25. Case Referred To	26. Reviewing Supervisor, Code, Date		

Charlotte Mecklenburg Police Department Supplement Report ©				COMPLAINT NUMBER 20170126131803	Page # 56 of 57
2. Victim Name Josue Javier Diaz			3. Original Offense / Charge OIS		
4. Location Of Offense 6200 Albemarle Road			5. Arrest Number	6. C.R. Number	
7. Original Report Date 01-26-2017	8. Supplement Date 01-27-2017		9. Correct Incident Classification		
10. Juvenile Case No	11. Multiple Case Clearance No	12. Supplement Confidential Yes	13. Purpose Of Supplement Interview with Detective [REDACTED]		

the...patrol car cause they told me leave it there and we're gonna collect it so I placed it there and that was it.

Hefner: Okay. Um so the officers left you with your gun?

[REDACTED] Yes.

Hefner: Okay and I've watched the bodycam footage, I've seen it's a...it's chaos. Was it safe to say they did that so you'd have some sort of recourse if things went bad, you'd at least have some way to defend yourself if something else went down?

[REDACTED] Yes.

Hefner: Okay um...and when...and eventually, I believe, you correct me if I'm wrong, you were removed from the first Police car and put into some other vehicle and brought here?

[REDACTED] In one of our vehicles.

Hefner: One...one of your vehicles, meaning an undercover vehicle?

[REDACTED] Yes.



Hefner: And brought to the Law Enforcement Center?

[REDACTED] That's correct.

Hefner: Um and your gun remained there at the...

[REDACTED] At the scene.

21. UCR Clearance Status <input type="radio"/> Open <input type="checkbox"/> By Arrest <input type="checkbox"/> Exceptional <input type="checkbox"/> Unfounded		23. Reporting Officer M.L. Hefner	Code 4764 Homicide	Assignment 01-27-2017	Date
22. Investigative Status <input type="checkbox"/> Active <input type="checkbox"/> Inactive <input type="checkbox"/> Closed <input type="checkbox"/> Administrative		25. Case Referred To	26. Reviewing Supervisor, Code, Date		

Charlotte Mecklenburg Police Department Supplement Report ©			COMPLAINT NUMBER 20170126131803	Page # 57 of 57
2. Victim Name Josue Javier Diaz		3. Original Offense / Charge OIS		
4. Location Of Offense 6200 Albemarle Road		5. Arrest Number	6. C.R. Number	
7. Original Report Date 01-26-2017	8. Supplement Date 01-27-2017	9. Correct Incident Classification		
10. Juvenile Case No	11. Multiple Case Clearance No	12. Supplement Confidential Yes	13. Purpose Of Supplement Interview with Detective 	

Hefner: ...in...in the Police car at the scene? Okay, alright um...

 That's what I was told to do <Talkover - inaudible>

Hefner: Sure, sure, absolutely. Um okay <Inaudible>

Laughrun: And...and the dope was still there too wasn't it?

 Yes.

Hefner: It was turned in, I can tell you it was turned in I...I've learned that since then um...I did see um...uh heroin in a text message and I was concerned as to were that came from <Inaudible>...understanding that was something from your operation. Is that what you...you had...evidence from the prior case you had worked still in your city vehicle?

 Yes.

Hefner: Is what I'm...is I'm...what I'm referring to. Okay um... Anything else Mr. Laughrun?

Laughrun: No sir, thank you.

Hefner: Okay. This will conclude the recording, the current time is uh 1654.

MLH/JDF/rge

Reviewed by Detective M.L. Hefner on 01-31-2017.

1. UCR Clearance Status <input type="checkbox"/> Open <input type="checkbox"/> By Arrest <input type="checkbox"/> Exceptional <input type="checkbox"/> Unfounded		23. Reporting Officer M.L. Hefner	Code Assignment 4764 Homicide	Date 01-27-2017
22. Investigative Status <input type="checkbox"/> Active <input type="checkbox"/> Inactive <input type="checkbox"/> Closed <input type="checkbox"/> Administrative		25. Case Referred To	26. Reviewing Supervisor, Code, Date	

Exhibit 2

[Reviewed / Corrected by DS Osorio #1176]

DO = Detective D. S. Osorio

JV = Javier Valiente

DO: OK TODAY'S DATE IS, UH, THURSDAY, JANUARY 26th, 2017. THE TIME RIGHT NOW IS 6:06, UH, P.M. MY NAME IS DETECTIVE D. OSORIO WITH CHARLOTTE MECKLENBURG POLICE DEPARTMENT. PERSON BEING INTERVIEWED RIGHT NOW IS JAVIER, J-A-V-I-E-R, VALIENTE, V-A-L-I-E-N-T-E, HISPANIC MALE, DATE OF BIRTH 10/17/1986. LIVES AT 6509 REGATTA, R-E-G-A-T-T-A, LANE HERE IN CHARLOTTE, NORTH CAROLINA, 28227. UHM, HE DOESN'T HAVE A CELL PHONE, UH, NO CONTACT INFORMATION. UHM, HE LIVES WITH A, UH, A FRIEND OR A ROOMMATE, GUADELOUPE VAL-, UH, VAL-, UH VAL-I-ENTE.

DO: Guadalupe, ¿Qué es de tí? Guadalupe, who is she to you?

JV: Amiga. Friend.

DO: OK, GUADELOUPE VALENTE WHO WAS JUST A FRIEND. UHM, HE'S ONLY BEEN HERE IN CHARLOTTE FOR THREE MONTHS. HE CAME FROM ATLANTA SO HE HAS BASICALLY HAS NO TIES HERE IN CHARLOTTE. UHM.

DO: ¿Tú hablas inglés? Do you speak English?

JV: No. No.

DO: ¿Para nada? Not at all?

JV: No. No.

DO: OK MR. VALIENTE, UH, DOES NOT SPEAK ANY ENGLISH AT ALL WHATSOEVER, SO THIS INTERVIEW IS GOING TO BE CONDUCTED IN SPANISH. I'M A SPANISH SPEAKING DETECTIVE. UHM, SO AGAIN, TIME RIGHT NOW IS 6:07 IN THE EVENING. UHM, INTERVIEW ROOM 2001, POLICE HEADQUARTERS.

DO: Ok, uh, Javier, Uhm, queremos hablar contigo, tomar tus declaraciones acerca de lo que pasó hoy. ¿Verdad? Ok, uh, Javier. Uhm, we want to talk to you, to take your statement about what happened today. Right?

JV: Sí. Yes.

DO: Uhm, en tus, en tus palabras. ¿Con quién era la persona con quien tú venías hoy en el carro? Uhm, in your, in your words. Who was the person who came with you today in the car?

JV: Con Josué. With Josué.

DO: Josué. Josué.

JV: Josué Díaz. Josué Díaz

DO: ¿Díaz? Díaz?

JV: Sí. Yes.

DO: ¿Y con "s" o "z"? And with an "s" or a "z"?

JV: Con "z" creo. Sí, con "z." With a "z," I think. Yes, with a "z."

DO: ¿Y él venía manejando? **And he was driving?**

JV: Sí. **Yes.**

DO: ¿Qué clase de carro venían? **What kind of car did you come in?**

JV: En una camioneta. Una camioneta gris. Uh, era de trabajo. De trabajo. **In a pickup. A grey pickup. Uh, it was from work. From work.**

DO: ¿Uh, una troca o camioneta? **Uh, a truck or a camioneta?**

JV: Una troca. **A truck.**

DO: ¿Qué clase? **What kind?**

JV: Como una, que se, que se **Like a, that, that---**

DO: ¿Un “pickup truck” o un SUV? **A pickup truck or an SUV?**

JV: Como un, un SUV. **Like a, an SUV.**

DO: ¿SUV? **SUV?**

JV: Sí. **Yes.**

DO: OK. ¿Te sabes la marca? **OK. Do you know what brand?**

JV: No. Es, es la primera vez que, que, que me subí ahí. **No. It, it was the first time that, that, that I got in it.**

DO: OK ¿Y cómo es que tú conoces a, a Josué? **OK. And how do you know Josué?**

JV: Lo conozco por medio de un amigo. Por trabajo. **I know him through a friend. From work.**

DO: ¿Por qué en el trabajo, trabajo, trabajan juntos? **From work, work do you work together?**

JV: Sí. **Yes.**

DO: ¿Trabajaron hoy juntos? **Did you work together today?**

JV: Uhm, sí. Trabajamos. **Uhm, yes. We worked.**

DO: ¿De dónde venían? **Where did you come from?**

JV: Uh, de trabajar en el “drywall”. **Uh, from working on drywall.**

DO: OK ¿Y quién es el patrón de ustedes del “drywall”? **OK. And who is your boss for the drywall?**

JV: Uhm, pues él tiene varios, varios---este--- patrones. **Uhm, well, he has, several, several--- these--- bosses.**

DO: Uhm **Uhm**

JV: Sí, pero, este, venimos en un específico de que su papá le había pasado una casa para, para trabajar. Porque su patrón trabaja ahí mismo. **Yes, but, this, we came from a specific one, that his dad had passed on to him a house to work on. Because his boss works there.**

DO: ¿El papá de de Josué? **Josué’s dad?**

JV: Sí. **Yes.**

DO: Ok. Y---él---¿dónde estaban trabajando hoy? **Ok. And---he--- where were you working today?**

JV: Estábamos acá por la,---por la ¿Wendover? **We were here around---Wendover?**

DO: ¿Wendover? **Wendover?**

JV: Mhmm **Mhmm**

DO: ¿En una casa, apartamentos o qué? Qué trabajo? **In a house, an apartment, or what? What work?**

JV: Casa, casa. **A house, a house.**

DO: ¿Qué estaban haciendo? **What were you doing?**

JV: Lijamos las casas. Lijamos las casas de. Las casas nuevas. **We were sanding the houses. We sanded the houses of. The new houses.**

DO: Mmhmm **Mmhmm**

JV: Sí **Yes**

DO: ¿Qué es, qué es--- lijamos? **What is, what is sanding?**

JV: Lijar es--- como--- **Sanding is like---**

DO: Drywall? ¿Trabajo en el drywall? **Drywall? Working on the drywall?**

JV: Ajá. **Yes.**

DO: ¿Habían puesto el drywall en la casa nueva? **Had you put the drywall in the new home?**

DO: Sí **Yes**

JV: Ok **Ok**

JV: Ajá. Ya, lijamos para los pintores--- **Yes. And we sand it for the painters---**

DO: Para los pintores. **For the painters.**

JV: Sí **Yes**

DO: Entonces cuando ya le han puesto el drywall y, y, y el “mud” y todo eso, se lija para que esté listo para la pintura. **Then when the drywall has already been put up and, and , and the mud and all that, then you sand it so it’s ready for painting.**

JV: Exacto. **Exactly.**

DO: ¿Y eso es lo que estaban haciendo hoy? **And that’s what you were doing today?**

JV: Sí. **Yes.**

DO: Ok. En una casa sobre la Wendover. **Ok. In a house on Wendover.**

JV: Mmhmm. **Mmhmm.**

DO: Ok. ¿Y tú y Josué han estado trabajando juntos todo el día hoy? **Ok. And you and Josué had been working together all day today?**

JV: Sí. **Yes.**

DO: OK. ¿Y acababan de salir? ¿Venían saliendo del trabajo o qué? **Ok. And you all just got off? Did you all leave work or what?**

JV: Veníamos al lonche. **We were going to have lunch.**

DO: ¿Iban al al lonche? **You went for for lunch?**

JV: Ajá **Yes**

DO: ¿Dónde iban a lonchar? **Where did you go for lunch?**

JV: A casa de él. **His house.**

DO: ¿A la casa de, de Josué? **To the house of, of Josué?**

JV: Ajá. **Yes.**

DO: ¿Él vive en casa o apartamento? **Does he live in a house or an apartment?**

JV: En un tráiler. **In a trailer.**

DO: Ok. ¿Has ido a su tráiler antes? **OK. Have you been to his trailer before?**

JV: Sí. **Yes.**

DO: ¿Y dónde queda? ¿Dónde queda donde él vive? **And where is it? Where does he live?**

JV: Él vive por la Wendover. **He lives by Wendover.**

DO: ¿Wendover Road? **¿Wendover Road?**

JV: Mmhmm **Mmhmm**

DO: ¿Hay tráilers por allá? **Are there trailers there?**

JV: Sí. **Yes.**

DO: Ok. ¿Es un parque de tráilers? **OK. Is it a trailer park?**

JV: Mmhmm. **Mmhmm.**

DO: Ok. Entonces él iba manejando y tú ibas en el pasajero. **Ok. So he was driving and you were in the passenger seat.**

JV: Sí. Yo iba de pasajero. **Yes. I was in the passenger seat.**

DO: ¿Y qué fue lo que pasó? ¿Qué sucedió? **And what was it that happened? What happened?**

JV: Porque, este---Estaba una una camioneta, una camioneta gris y, y se nos apareó, y nos empezó a gritar. Y como, este, Josué, este, él tiene una pistola, pero con permiso porque él es, es, él es ciudadano de aquí. **Because, this--- There was a truck, a grey SUV and, and it came next to us, and he started screaming at us. And since, this, Josué, this, has a gun, but with a permit, because he is, he is a citizen here.**

DO: Ok, entonces, entonces el carro gris--- **OK, then the grey car ---**

JV: Mmhmm **Mmhmm**

DO: El carro gris. Ah. **The grey car. Ah.**

JV: Iba a rebasarnos---así. **He was going to overtake us ---, like that.**

DO: Ok. **Okay.**

JV: Mmhmm **Mmhmm**

DO: Ok ¿Como los estaba pasando? **Okay. So he was passing you?**

JV: Ajá. Exacto. Nos iba pasando y--- **Yes. Exactly. He was passing us and---**

DO: Hum. **Hum.**

JV: Nos iba pasando y---este **He was passing us and ---this.**

DO: ¿Los cortado o algo? **He cut you off or something?**

JV: Nos cortado ajá, sí, y nos empezó a gritar y, como Josué carga, cargaba su pistola. Siempre la cargaba, sí, porque, la policía siempre le ha dicho que como tiene permiso lo tiene que traer a la luz, así, a la vista--- **Yes, he cut us off and then he started screaming at us, and, since Josué was carrying his gun. He always had it because the police had always told him that since he has a permit he has to have it out in the open, in sight ---**

DO: Mmhmm **Mmhmm**

JV: Ajá **Mmhmm**

DO: ¿Qué clase de pistola era? **What kind of gun was it?**

JV: Es una pequeñita, de esas pequeñitas de bolsillo. **A tiny, tiny pocket type.**

DO: Mmhmm ¿De qué color? **Mmhmm. What color?**

JV: Cromada, cromadita así pero pequeñita. **Chrome, kind of chrome like this, but tiny.**

DO: Mmhmm. **Mmhmm.**

JV: 22 **A 22.**

DO: ¿Cómo un 22? **Like a 22?**

JV: Como un 22. Sí **Like a 22. Yes**

DO: ¿Seguro que era un 22? **Are you sure it was a 22?**

JV: Sí. **Yes.**

DO: Ok. ¿Tú la habías visto antes? **Okey. Have you seen it before?**

JV: Sí. **Yes.**

DO: Ok ¿Tú la habías tomado en la mano antes para verla? ¿Él te la había enseñado? **Ok. Have you taken it in your hand before to look at it? Had he shown it to you?**

JV: No yo nunca la tomé pero si la había visto. **No, I never took it but I have seen it.**

DO: Ok. **Ok.**

JV: Mmhmm. **Mmhmm.**

DO: Y luego, y luego, entonces, ¿dónde fue que pasó eso? **And then, and then, so where was it that that happened?**

JV: En, en la luz, en la luz fue. **At the light. It was at the light.**

DO: En la Albemarle **At Albemarle?**

JV: Sí. **Yes.**

DO: Ok ¿Cuál luz? ¿Sabes? **Ok. What light? Do you know?**

JV: Estábamos dando vuelta para--- **We were turning onto---**

DO: ¿La Central? **Central?**

JV: para Central, como pulgarcito, un lugar--- **Central, like El Pulgarcito, a place ---**

DO: ¿Reddman? **Reddman?**

JV: Mmhmm. **Mmhmm.**

DO: Donde, donde vienen los carros y corren para allá para la Central. **Where, where the cars come and run over there to Central.**

JV: Exacto. Ajá **Exactly. Yes.**

DO: Pero ustedes venían de la otra dirección. ¿Verdad? **But you were coming from the other direction. Right?**

JV: Sí. **Yes.**

DO: Ok. Entonces iban pasando ahí y este, este carro--- **Ok. Then they were going there and this, this car ---**

JV: En, en, en la luz empezaron a gritar y, empezaron, y pues sacaron, sacaron pistola. **At, at, at the light they started screaming and started, and then they pulled, pulled out a gun.**

DO: Mhmm. ¿Quién paró primero? **Mhmm Who stopped first?**

JV: Uh, el paró primero **Uh, he stopped first.**

DO: ¿Quién es él? **Who is he?**

JV: Josué. **Josué.**

DO: ¿Josué paró su carro? **Josué stopped his car?**

JV: Sí. Paró su carro y abrió su puerta---para para hablar con él. **Yes. He stopped his car and opened his door --- to, to talk to him.**

DO: Mhmm. ¿Había mucho tráfico que Josué tenía que parar, o--- **Mhmm. Was there a lot of traffic that Josué had to stop, or---**

JV: Sí, había mucho tráfico. **Yes, there was a lot of traffic.**

DO: ---o, o Josué podía haber seguido con..? **--- or, or could Josué have continued?**

JV: No, no, no. Había mucho tráfico. **No. There was a lot of traffic.**

DO: Entonces tuvo que parar por el tráfico, y luego--- **Then he had to stop because of the traffic, and then ---**

JV: Sí. Para hablar con él.. **Yes. To talk with him.**

DO: Mhmm. **Mhmm.**

JV: Mhmm. Pero ya él se--- el otro, el otro chavo gritó que era policía **Mhmm. But the other guy shouted that he was a police officer.**

DO: ¿Cuándo Josué se salió del carro--- **When Josué left the car---**

JV: Mhmm. **Mhmm.**

DO: ---tenía la pistola en la mano? **---he had the gun in his hand?**

JV: No. En su bolsa. **No. In his pocket.**

DO: Ok. Entonces se había puesto la pistola en la bolsa. **Ok. Then he had put the gun in his pocket.**

JV: En la bolsa. Sí. Es donde la tenía. Mhmm. **In his pocket. Yes. That's where he had it. Mhmm.**

DO: Ok. **Ok.**

JV: Y ya este. Cuando Josué intentó hablar con él, el otro también sacó pistola y ya, y empezó a tirar. **And when Josué tried to talk to him, the other guy also pulled out a gun and, and started to shoot.**

DO: Mhmm. **Mhmm.**

JV: Empezó a tirar. **Started to shoot.**

DO: ¿La otra persona dijo, dijo que era policía? **The other person said, said he was a police officer?**

JV: Sí. **Yes.**

DO: ¿Cuándo él se salió del carro dijo "Policía"? **When he left the car, he said "Police?"**

JV: I'm police, dice, I'm Police. **I'm police, he said, I'm police.**

DO: Mhmm. **Mhmm.**

JV: Sí **Yes.**

DO: Ok. Entonces, cuándo él dijo “I’m police”, ¿qué hizo Josué? **Ok. So when he said “I’m police,” what did Josué do?**

JV: Josué no, no sacó la pistola. **Josué did not, not draw his gun.**

DO: Mmhmm **Mmhmm.**

JV: No la sacó. Solo se quedó así. **He did not draw it. He just stayed like that.**

DO: Mmhmm ¿Él nunca sacó la pistola? **Mmhmm. He never took out his gun?**

JV: Él nunca sacó la pistola. Y, y, y ya cuando le pegó a mi amigo, ya después se fue sobre mí. **He never took out his gun. And then when he hit my friend, he came over to me.**

DO: Mmhmm. **Mmhmm.**

JV: Que yo estaba dentro. Yo estaba dentro del carro. Y también se metió a amenazarme con la pistola. **I was inside. I was in the car. And he also started to threaten me with the gun.**

DO: ¿Qué dijo? **What did he say?**

JV: Me dijo. Me dijo, este, “Get out of the car”, “Get out of the car”, dijo. Sal del carro, **He said to me. He said “Get out of the car,” Get out of the car he said. Get out of the car---**

DO: Mmhmm. **Mmhmm.**

JV: ---y que no me moviera. Le digo “man”, le digo que yo no tenía nada. **---and not to move. I said, Man, I said, I don’t have anything.**

DO: Mmhmm. **Mmhmm.**

JV: Solo venimos de trabajar. Pero ya ya--- **We’re just coming from work. But it already, already---**

DO: ¿Y tú qué hiciste? ¿Saliste del carro? **Mmhmm, and what did you do? Did you get out of the car?**

JV: No, no. Yo no salí, yo ahí me quedé. **No, no. I didn’t get out, I stayed.**

DO: OK ¿Pusiste las manos arriba, abajo? **OK Did you put your hands up, down?**

JV: No, las manos, arriba las puse. **No, I put them up.**

DO: Cuando él, cuando esta persona salió sobre ti, uh ¿también te dijo a ti que era policía? **When this person came to you, uh, he also told you he was a police officer?**

JV: Sí. **Yes.**

DO: Ok. ¿Cómo te dijo? **OK. What did he say to you?**

JV: También lo mismo, que era policía. **The same thing, that he was a police officer.**

DO: ¿Police, police? **Police, police?**

JV: “Police”, sí, pero la verdad no sé si era policía. **“Police,” yes, but I really don’t know whether he was a police officer.**

DO: Mmhmm. Ok. Ahora, retrasemos un poco. Antes. Y, y quiero, quiero que me digas la verdad, no quiero, no quiero que mientas. **Mmhmm. Ok. Now, let’s go backtrack a little. Before. And, and I want, I want you to tell me the truth, I don’t want, I don’t want you to lie.**

JV: No. **No.**

DO: No quiero que mientas, uh, por Josué o por cualquier otra persona, porque--- **I don’t want you to lie, uh, for Josué or anyone else, because**

JV: No. No. **No. No.**

DO: ---tú estabas ahí pero también tienes que entender que había mucho tráfico--- **--- you were there but you also have to understand that there was a lot of traffic ---**

JV: Sí. **Yes.**

DO: Había muchas carr--- **There were a lot of---**

JV: Sí. **Yes.**

DO: Un momento. Había mucho tráfico, habían otros carros que estaban detrás de ti, habían mucha gente viendo lo que sucedió--- **Just a second. There was a lot of traffic. There were other cars that were behind you, there were a lot of people watching what happened---**

JV: Sí **Yes.**

DO: ---y hay testigos que dicen que, allá atrás en la luz, donde tú dices que salen los carros que van sobre la central, **---and there are witnesses who say that, back there at the light, where you say that the cars exit that go onto Central,**

JV: Mmhmm. **Mmhmm.**

DO: ---que, que Josué le pegó a ese carro primero por detrás, que hubo un accidente. Josué le pegó a ese carro, y luego que Josué salió corriendo a mucha velocidad tratando de huirse del accidente. ¿Sí o no? **---that, that Josué hit that car first from behind, that there was an accident. Josué hit that car first, and then Josué got out running full speed trying to flee the accident. Yes or no?**

JV: Sí. **Yes.**

DO: Ok. Gracias. **Ok. Thank you.**

JV: Sí **Yes.**

DO: Gracias. Porque esa es la verdad, ¿verdad? **Thank you. Because that's the truth, right?**

JV: Sí. **Yes.**

DO: Ok. Porque eso no fue lo primero que tu dijiste. Primero. Primero lo dijiste fue que este carro lo había cortado y que se estaban peleando, pero, pero lo que comenzó todo esto fue que Josué le golpeó a este carro primero allá. Y fue un accidente, ¿verdad? **Ok. Because that wasn't the first thing you said. First. What you said first was that this car had cut you off and they were fighting, but, but what started all this was that Josué had hit this car first. And it was an accident, right?**

JV: Sí, fue un accidente. **Yes, it was an accident.**

DO: Ok. **Ok.**

JV: Sí, este, pero no fue un---este ¿cómo cómo le diré---? **Yes, this. But, no, it was not a --- how, how do you say ---?**

DO: No fue un choque duro. **It was not a hard collision.**

JV: No, no, solo fue un, cómo se, un cómo un "push", así nada más. **No, no, it was only, how do you, a, like a push, nothing more.**

DO: ¿Pero fue un accidente? **But was it an accident?**

JV: Sí. **Yes.**

DO: Ok. Y luego Josué, en vez de parar,--- **Ok. And then Josué, instead of stopping,,**

JV: Se fue **He left.**

DO: ---se fue, ¿verdad? **---he left, right?**

JV: Sí. **Yes.**

DO: Ok. Porque eso que todo, que toda la gente dice--- **Ok. Because that's what everyone, what everyone says---**

JV: Sí **Yes**

DO: ---que Josué en vez de haber parado---salió **..that Josué, instead of having stopped --- he got out**

JV: Yo no tengo por qué mentir. **I don't have any reason to lie.**

DO: No, tú no más eras el pasajero. **No, you were just the passenger.**

JV: Mmhmm. **Mmhmm.**

DO: Tú estás bien. Gracias. Agradezco que me digas la verdad. Ok. Pero. ¿Por qué? ¿Por qué no paró Josué? ¿Por qué no más, paró en vez de salir huyendo del choque? **You're fine. Thank you. I appreciate that you're telling me the truth. Ok. But. Why? Why didn't Josué stop? Why didn't he stop instead of getting out fleeing from the crash?**

JV: Hum. No sé, él llevaba prisa, porque le dije "estacionate o hazte a un lado". **Hum. I don't know. He was in a hurry, because I said "pull over or move to the side."**

DO: Mmhmm. **Mmhmm.**

JV: Mmhmm. **Mmhmm.**

DO: ¿Y qué te decía Josué cuando estaba tratando de, de salir a mucha velocidad? **And what did Josué say to you when he was trying to get away at high speed?**

JV: Dice, dice solo nos vamos a estacionar en el restaurant y ahí vamos a arreglar las cosas. Pero la luz, la luz se puso primero. La luz se puso primero. Ya estábamos en un lugar que se llama "Pulgarcito". Ahí nos íbamos a estacionar, **He says, he says we're just going to park at the restaurant and we'll sort things out there. But the light, the light changed first. We were in a place called "Pulgarcito." That's where we were going to park,**

DO: Mmhmm. **Mmhmm.**

JV: ---porque ahí siempre comemos---pero la luz se puso antes y ya no, y ya no. Ahí pasó todo eso. **---because we always eat there--- but the light changed first and we couldn't, we couldn't anymore. All that happened there.**

DO: Mmhmm. ¿Qué te decía Josué cuando, cuando lo iba siguiendo este carro después del accidente? **Mmhmm. What did Josué say to you when, when that car was following him after the accident?**

JV: ¿Después del accidente? **After the accident?**

DO: Mmhmm. Después del primer accidente, cuando le pegó al carro. ¿Qué decía Josué? **Mmhmm. After the first accident when he hit the car. What did Josué say?**

JV: Yo le dije. Mira ahí nos viene detrás el carro. Dijo: Sí, ahorita nos vamos a, a este, a estacionar para, para hablar con él y arreglar las cosas. **I told him. Look, there comes the car behind us. He said: Yes, right now we're going to park, to, to talk to him and sort things out.**

DO: Mmhmm. **Mmhmm.**

JV: Mmhmm. **Mmhmm.**

DO: Pero no, pero no hizo eso. **But, but he didn't do that.**

JV: Pero ya no, ya no pasó eso. **But that's not, that's not what happened.**

DO: Es que él estaba tratando de escaparse de ese carro también. **It is that he was trying to escape from that car as well.**

JV: Porque la luz ya, no, porque la luz se puso antes, **No, because the light changed first,**

DO: Mmhmm **Mmhmm.**

JV: Así que cuando pasó eso ya fue en la luz. Ya no fue, ya no fue este--- ya no fue--- ya no nos dio tiempo de llegar al restaurant. **So when that happened, he was already in the light. It was no longer, it was no longer--- it was not--- it no longer gave us time to get to the restaurant.**

DO: Mmhmm. **Mmhmm.**

JV: Así es. **That's it.**

DO: Ahora. Tú dices que Josué siempre tiene la pistola, ¿adónde? ¿Adónde en el carro? **Now. You say that Josué always has the gun—where? Where in the car?**

JV: A la luz ahí. A la luz. **Out in the open. Out in the open.**

DO: ¿Dónde tenía la pistola? ¿En qué parte del carro tenía la pistola? **Where was the gun? In what part of the car?**

JV: En la--- ¿Cómo se dice? Arriba de la guantera. Porque muchas veces ya lo han parado--- **In the --- what do you call it? Above the glovebox. Because often he has been stopped---**

DO: Mmhmm **Mmhmm.**

JV: Así la policía, pero como él es residente--- **By the police, but since he's a resident**

DO: Mmhmm **Mmhmm.**

JV: Pues, este **So, this**

DO: No más que esté visible. **It just has to be visible.**

JV: Tú tienes tus papeles. Es lo que le dicen Tú tienes que traer tu (unintelligible). **You have your papers. It's what they tell him, you have to carry your (unintelligible).**

DO: Tiene que estar visible. **It has to be visible.**

JV: No lo tienes que traer escondido. **You just don't want to carry it hidden.**

DO: Sí, sí, exactamente. **Yes, yes, exactly**

JV: Así es. **That's it.**

DO: Entonces, pero, cuando salió Josué del carro, ¿por qué agarró la pistola? **So when Josué came out of the car, why did he grab the gun?**

JV: Uh. Por miedo, yo pienso, no sé. **Uh. Out of fear, I think; I don't know.**

DO: Mmhmm. **Mmhmm.**

JV: Mmhmm **Mmhmm.**

DO: Ok **Ok**

JV: Pero no la agarró, no la agarró, así, en la mano, la agarró, solo la traía en la bolsa, como. **But he didn't grab it, he didn't grab it like that, in his hand; he grabbed it, he only carried it in his pocket, like.**

DO: ¿Y si hay testigos que estaban ahí que que Josué salió con el arma en la mano? **What if there are witnesses who were there who say that Josué came out with the gun in his hand?**

JV: Eso sí no sé, porque yo me quedé dentro del carro, **I don't know about that, because I was in the car,**

DO: Mmhmm. **Mmhmm.**

JV: yo no me moví para nada, yo solo estaba ahí. **I didn't move at all, I was alone in there.**

DO: Sí. Entonces tú no sabes si Josué tenía el arma en la mano o en la bolsa. **Yes. So you don't know if Josué had the gun in his hand or in his pocket.**

JV: No. **No.**

DO: ¿Verdad? ¿Sabes o no sabes? **True? You know or you don't know?**

JV: No. No sé, la verdad. **No. I don't know, truthfully.**

DO: ¿Oíste, oíste tiros? **Did you hear, did you hear shots?**

JV: Sí. **Yes.**

DO: ¿Cuántos tiros oíste? **How many shots did you hear?**

JV: Tres. **Three.**

DO: ¿Tres tiros? **Three shots?**

JV: Sí. **Yes.**

DO: Ok. **Ok.**

JV: Pero de, de, de--- **But from, from, from ---**

DO: ¿Qué oíste lo que, lo que, el carro atrás, el muchacho del carro de atrás? **What did you hear from the guy in the car behind?**

JV: Él no se bajó del carro para nada. **He never left the car at all.**

DO: ¿No? **No?**

JV: No. **No.**

DO: ¿Tú crees que disparó desde su carro, sentado? **Do you think he shot from his car, seated?**

JV: Sí, así nada más. **Yes, like that, that's all.**

DO: ¿Tú lo viste? **You saw it?**

JV: Sí, del retrovisor. **Yes, in the rearview mirror.**

DO: Uh. **Uh.**

JV: Ya cuando lo vi, ya se había caído. **When I saw him, he had already fallen.**

DO: ¿Ya se había caído Josué? **Josué had already fallen?**

JV: Sí. **Yes.**

DO: Ok. Y cuando se cayó Josué, ¿tú viste si tenía un arma en la mano? ¿O no podías ver? **Ok. And when Josué fell, you saw whether he had a gun in his hand? Or were you not able to see?**

JV: No, no. No. **No, no. No.**

DO: ¿No o no podías ver? **No? Or you couldn't see?**

JV: No podía ver. **I couldn't see.**

DO: Ok. **Ok.**

JV: No podía ver y no lo miré. **I could not see and I didn't look at him.**

DO: Uhuh. Porque hay alguna razón que--- **Uhuh. Because there is a reason ---**

JV: Yo me espanté también. Usted sabe. **I was also scared. You know.**

DO: Sí, por lo que estaba sucediendo. **Yes, because of what was happening.**

JV: Sí. **Yes.**

DO: ¿Pero tú oíste que la persona de atrás dijo “Police”? **But you heard the person behind you say “Police?”**

JV: Sí. **Yes.**

DO: Police. **Police.**

JV: Sí. **Yes.**

DO: ¿Y cómo dijo? ¿“Police, Police”, o, ¿no más una vez, dos veces? **And how did he say it? “Police, Police,” just once, twice?**

JV: Dijo, “I’m police” **He said, “I’m police.”**

DO: Did he say, “drop the gun?” **Did he say, “drop the gun?”**

JV: No, nada más dijo “I’m police”, **No, nothing more, he said “I’m police,”**

DO: I’m police? **I’m police?**

JV: Ajá. **Yes.**

DO: Ok. **Ok.**

JV: Pero no se creía pues no venía vestido de policía. **But I didn’t believe it because he wasn’t dressed like a policeman.**

DO: Mmhmm **Mmhmm.**

JV: No sé, la verdad, si será o no será. **I don’t know if it’s true or not.**

DO: Ok. Pero también, donde tú estaba adentro de la troca, tú no podías ver si Josué tenía la pistola en la mano. **Ok. But, also, where you were inside the truck, you couldn’t see if Josué had the gun in his hand.**

JV: No. **No.**

DO: Uhm. Cuando él salió de la troca, ¿Por qué salió de la troca? ¿Por qué no más se quedó dentro de la troca Josué? ¿Por qué? **Uhm. When he got out of the truck, why did he get out of the truck? Why didn’t Josué stay inside the truck? Why?**

JV: Él decía que quería hablar con él, que que--- **He said he wanted to talk to him, that, that---**

DO: Pero, pero no se iban a arreglar las cosas ahí, en el medio de la carretera. ¿Verdad? **But, but they weren’t going to work things out in the middle of the road. Right?**

JV: No, claro que no. **No, of course not**

DO: Mmhmm. **Mmhmm.**

JV: Pero--- **But---**

DO: ¿Por qué crees que salió Josué? **Why do you think Josué got out?**

JV: Porque pues, porque él es un chavo así que, no, ¿cómo te diré? No es violento. Pues. **Because he’s a guy like that, how can I say --- He’s not violent. So.**

DO: ¿Josué no es violento? **Josué isn’t violent?**

JV: No. Y que yo sepa él no tiene record ni nada de eso. **No. And I know he doesn’t have a record or anything like that.**

DO: Mmhmm **Mmhmm.**

JV: Y cualquier problema siempre lo dialoga así. **And anytime there’s a problem, he always talks it out, like that.**

DO: Mmhmm. **Mmhmm.**

JV: Así es. **That's it.**

DO: ¿Cuánto tiempo tienes tú que lo conoces? **How long have you known him?**

JV: Ya tengo mucho tiempo. Estuve viviendo en Atlanta pero, este, vine para acá, **For a long time. I was living in Atlanta but I came here**

DO: Mmhmm. **Mmhmm.**

JV: Uhm como en el 2004. **Uhm like around 2004.**

DO: Mmhmm. **Mmhmm.**

JV: Y desde ahí lo conozco. **And I've known him since then.**

DO: ¿Desde el 2004? **Since 2004?**

JV: Sí. **Yes.**

DO: Entonces ya tienes más de 10 años que lo conoces. **Then you've known him for more than 10 years.**

JV: Sí, sí y nunca, nunca había pasado eso. **Yes, and nothing like this has ever happened to him.**

DO: Mmhmm ¿Y Josué es nacido aquí? **And Josué was born here?**

JV: Sí **Yes.**

DO: ¿Adónde? **Where?**

JV: Es nacido en California. **He was born in California.**

DO: ¿En California? **In California?**

JV: Sí **Yes.**

DO: Ok. **Ok.**

JV: Toda--- **All---**

DO: ¿Josué no es pandillero? **Josué isn't a gang member?**

JV: Toda su vida aquí. **All his life here.**

DO: ¿Josué no es pandillero? **Josué isn't a gang member?**

JV: No **No**

DO: ¿Tiene tatuajes? **Does he have tattoos?**

JV: Sí. **Yes.**

DO: ¿Qué clase de tatuajes tiene? **What kind of tattoos does he have?**

JV: Ehh. Tiene---de, del pasado así. **He has --- from, from the past, like that.**

DO: Mmhmm. **Mmhmm.**

JV: Pero ya no anda en eso. **But he's no longer involved in that.**

DO: Pero no es pandillero, que tú sepas. **But he's not a gang member, as far as you know.**

JV: No. No. **No.**

DO: Ok. ¿Su familia de dónde es? **Ok. Where is his family from?**

JV: Él es, este, México-salvadoreño. **He is Mexican-Salvadoran.**

DO: Mmhmm. Así como yo, yo también. **Mmhmm. Just like me, me, too.**

JV: Sí, su papá es mexicano y su mamá es de El Salvador. **Yes, his father is Mexican and his mother is from El Salvador.**

DO: Mmhmm. **Mmhmm.**

DO: Mi mamá es de El Salvador también, **My mother is from El Salvador, too,**

JV: Oh. **Oh.**

DO: y mi papá es mexicano. **and my dad is Mexican.**

JV: Así es. **That's how it is.**

DO: Y yo soy de California. También. Mmhmm **And I'm from California. Too. Mmhmm.**

JV: ¿Se imagina? **Can you imagine?**

DO: Sí. **Yes.**

JV: Se imagina. Y, cómo le digo. Nunca había tenido problemas, siempre hemos andado trabajando. **And, like I'm telling you. I've never had problems, we've always gone out working.**

DO: Mmhmm. Pero lo que pasa es, lo que pasa es, primero, que si Josué hubiera parado su carro en el primer choque--- **Mmhmm. But what happens is, first, that if Josué had stopped his car at the first impact**

JV: Mmhmm **Mmhmm.**

DO: ---uhm, ese es el primer problema; el segundo problema, el segundo problema, es que, es que Josué como que se estaba tratando de escapar, uhm, y luego fue a dar con el tráfico y ya no, y ya no podía, ya no tenía para donde irse. Entonces, bueno, lo que debió haber hecho es hacerse a un lado, meterse en un parqueadero o algo y, y llamar a la policía para hacerse un reporte, ¿verdad? **---uhm, that's the first problem; the second problem is that Josué, since he was trying to get away and then had to deal with traffic and no longer, he no longer could, he no longer had anywhere to go. What he should have done is to move to one side, get into a parking lot, and, and call the police to make a report, right?**

JV: Sí. **Yes.**

DO: Pero también, uno no se puede saltar del carro armado con pistola tampoco, porque eso es, esa no es una situación--- **But also, you can't jump out of the car armed with a gun, either, because that's, that's not a situation---**

JV: Un delito--- **A crime---**

DO: Sí. Esa no es una situación donde uno va a sacar una pistola. ¡Es solo un choque! Nada más. Ni modo, ni modo, ni modo que que vaya a asaltar a alguien con un arma, por un choque. *I mean*, eso no se puede hacer tampoco, ¿verdad? **Yes. That's not a situation where you're going to draw a gun. It's just a collision! Nothing more. No way, no way, no way is, is anyone going to assault somebody with a gun because of a collision. I mean, that can't happen either, right?**

JV: Mmhmm. **Mmhmm.**

DO: Pero lo más importante es que, sí, la persona a quien él golpeó sí es oficial. **But the most important thing is that, yes, the person whom he hit is an officer.**

JV: Sí. **Yes.**

DO: Sí. Es oficial de la policía. Trabaja, trabaja en esos de---bueno. **Yes. He's a police officer. He works as those who---well.**

JV: ¿Encubierto? **Undercover?**

DO: Bueno. Sí, pero es oficial. Entonces, cuando él salió armado con la pistola, el oficial se tiene que defender, porque lo que él ve es alguien que lo acaba de chocar, alguien que está huyendo del choque, pero ahora ve a alguien que se ha salido de su carro, agresivo, con una pistola. Y él no sabe quién, él no sabe quién es Josué. **Well. Yes, but he's an officer. When he came out armed with the gun, the officer had to defend himself, because what he sees is someone who just had a collision, someone who is fleeing the crash, but now sees someone who has gotten out of his car, aggressive, with a gun. And he does not know who, he does not know who Josué is,**

JV: Y a pesar de todo, ¿cómo sigue él? **And after all that, what happened to him?**

DO: No sé, no sé, quién, ¿Josué?, No sé al momento. Voy a chequear pero no estoy seguro. Pero ese es el problema. **I don't know, I don't know who, Josué? I don't know right now. I will check but I'm not sure. But that's the problem.**

JV: ¿Ya avisaron a su familia? **Did you already tell his family?**

DO: Mhmm. Pero ese es el problema. Y todo esto yo creo se hubiera, todo esto se podía haber evitado [sic], si no más, cuando ocurrió el primer choque, cuando golpeó a este carro, se hubiera parado, como la ley dice, que se hubiera parado, uh, uh, y se salen los dos, y, y llaman a la policía, especialmente si no fue un choque grande, llaman a la policía, o se miran el daño y dicen, mira, todo está bien, o, o se hace un reporte de la policía, pero no se puede salir uno agresivo, **Mhmm. But that's the problem. And all this could have been avoided, if he had just, when the first crash occurred, when he hit this car, if he had stopped, like the law says, if he had stopped, both of them get out and call the police, especially if it was not a big collision, and, and you call the police, or you look at the damage and you say, look, everything is fine, or, or you make a police report, but a guy can't get out being aggressive,**

JV: Mhmm (unintelligible) **Mhmm. (unintelligible)**

DO: armado con una pistola. **armed with a gun.**

JV: De hecho él me dijo, tú quédate aquí, nada más voy hablar con él y ya. **In fact he told me, you stay here, I'm just going to talk to him and that's all.**

DO: Y se salió de carro, **And he got out of the car,**

JV: Y se salió del carro. **And he got out of the car.**

DO: ¿Pero se salió del carro con, con el arma? **But he got out of the car with, with the gun?**

JV: No creo, o no sé. Yo pienso que ahí los que fueron a hacer la investigación --- (unintelligible) --- encontraron arma a lo mejor dónde piensan que sí. **I don't believe, or I don't know. I think there, the ones who were doing the investigation, --- (unintelligible) --- they most likely found the weapon where they think one will be.**

DO: Y a lo mejor, yo no sé, **And maybe, I don't know,**

JV: ¿Verdad? **Right?**

DO: yo no sé, pero, pero, pero tú no viste si tenía arma o no cuando se salió de carro. **I don't know, but, but, but you didn't see if he had a weapon or not when he got out of the car.**

JV: .No, yo no vi eso. **No, I didn't see that.**

DO: Entonces puede ser que haya tenido. Tú no viste. **Then it may be that he had one. You didn't see.**

JV: No, Yo no lo vi. Porque siempre, te digo, siempre lo tenía en su carro, así. **No, I didn't see. Because always, I tell you, he always had it in his car, like that.**

DO: Ok. Pero cuando él se salió, tú no, tú no viste el arma. **Ok. But when he got out, you didn't, you didn't see the gun.**

JV: Yo no vi el arma, no. **I didn't see the gun, no.**

DO: Ok. ¿Él siempre anda al arma? **Ok. Does he always carry the gun?**

JV: Sí. Siempre, pues como lo tiene con papeles y todo. Y no--- **Yes. Always, because, since he has papers and everything. And not ---**

DO: Y no hay problema con eso. Pero también, si él tiene permiso de tener el arma, **And there's no problem with that. But also, if he has a permit to have the weapon,**

JV: No sí, él---(unintelligible)--- **Yes, he---(unintelligible)---**

DO: él también debería saber que el arma no se saca nada más para espantar o nada más que para decir "tengo arma", tiene que haber, tiene que haber--- **he also should have known that you don't just pull out the weapon to scare someone or just to say "I have a weapon," it has to be something ---**

JV: "un motivo muy fuerte" **"a very strong reason"**

DO: ---tiene que haber una situación de vida o muerte, que uno se pueda defender en ese ejemplo de vida y muerte para poder sacar un arma, ¿verdad? ---**it has to be a life or death situation, in which you can defend yourself, in this example of life and death, to be able to draw a weapon, right?**

JV: Sí. Sí. **Yes. Yes.**

DO: Es como que yo te de una cachetada, ni modo que tú me vas a sacar el arma y que me vas a disparar porque te di una cachetada, eso no se puede hacer, ¿verdad? **It's like I give you a slap; no way are you going to draw the weapon and shoot because of a slap, you can't do that, right?**

JV: No. No.

DO: También es igual en un choque, Nada más porque nos chocamos, no quiere decir--- **It's the same thing with a crash, just because we hit each other doesn't mean ---**

JV: De hecho, de hecho, de hecho el choque no fue ni tanto, nada más, nada más fue como un, un "pushing" así. **In fact, in fact, in fact the crash wasn't even much, it was no more than, no more than a, a "pushing," like that.**

DO: Entonces hubiera parado y arreglar las cosas con esa persona, en vez de huir o tratar de huirse de, del accidente, eso es un crimen, eso se llama "hit and run". Ya, entonces. Pero agradezco que tú hayas---que me digas la verdad, ¿ok? **Then had he stopped and worked things out with that person, instead of running away or trying to flee the, the accident, that's a crime, that's called "hit and run." But I appreciate that you've --- thank you for telling me the truth, ok?**

JV: Sí. **Yes.**

DO: Uhm. Dame un, dame un momento. ¿Hay algo más que tú nos quieras decir acerca de lo que tú viste? **Uhm. Give me, give me a moment. Is there anything else you'd like to say to us about what you saw?**

JV: No pues, nada más, quería mirarlo cómo estaba pero ya no lo pude mirar, ya no me dejaron, Ya no me dejaron, este, mirarlo. Porque me esposaron y digo, ¿por qué me están esposando si yo no tengo nada que ver ahí? **No, nothing more, I wanted to look at him to see how he was but they wouldn't let me. They wouldn't let me look at him. Because they handcuffed me and I said, why are you handcuffing me if I'm not involved there?**

DO: Bueno, los oficiales también están tratando de, de figurar qué está sucediendo también. **Well, the officers are also trying to figure out what is happening.**

JV: Mhmm. **Mhmm.**

DO: Así que por la seguridad de todos--- no saben si hay más pistolas en el carro en que ustedes venían o qué. **So for everybody's safety --- they don't know if there are more guns in the car you came in.**

JV: Sí. **Yes.**

DO: Por eso te pusieron las esposas, pero después te las quitaron. **That's why they put the handcuffs on, but afterwards they took them off.**

JV: Sí, sí, me las quitaron. **Yes, they took them off me.**

DO: Ok. **Ok.**

JV: Pero ya de ahí ya no miré nada, **But I didn't see anything afterwards;**

DO: Ok. **Ok.**

JV: ---no miré nada, el oficial me trajo para acá. **---the officer brought me here.**

DO: Mmhmm. All right. Cuándo. Otra pregunta, explicame, cuando, cuando ustedes iban a lunchar, ¿tú viste si el andaba la pistola, Josué? **Mmhmm. All right. Another question, explain to me, when, when you were going to lunch, did you see him carrying the gun, Josué?**

JV: Sí, él siempre la cargaba. **Yes, he always carried it.**

DO: ¿Adónde? ¿Adónde? ¿La cargaba en su cuerpo o en el carro? **Does he carry it on his person or in the car?**

JV: En su carro, siempre. Así, a la luz siempre. **In his car. Like that, always out in the open.**

DO: Ok, ¿Adónde estaba exactamente en el carro? **Ok, where exactly was it in the car?**

JV: En el tablero, así. **On the dashboard, like this.**

DO: ¿Dónde yo manejo? **Where I drive?**

JV: Sí. Donde tú manejas, así, arriba, así. **Yes. Where you drive, like this, on top, like this.**

DO: Así arriba, ok y ahí es donde siempre está la pistola. **On top, ok, and that's where the gun is at all times.**

JV: Sí. **Yes.**

DO: Entonces, cuando él se salió del carro--- **Then, when he got out of the car ---**

JV: Yo no miré si él la agarró. **I didn't look to see if he grabbed it.**

DO: Tú no miraste si él la agarró o no. **You didn't look to see if he grabbed it or not.**

JV: No, yo no miré. **No, I didn't look.**

DO: All right. Pero tú, hoy, ¿tú la habías visto ahí? **But you, today, you saw it there?**

JV: Sí. Él siempre la tenía. **Yes. He always had it.**

DO: Hoy, cuando se iban a lunchar, o cuando tú estabas en el carro con él, **Today, when you all went to lunch, or when you were in the car with him,**

JV: Sí. **Yes.**

DO: ¿tú habías visto la pistola en frente del tablero? **Did you see the gun in front of the dashboard?**

JV: ¿Del tablero? Sí. **The dashboard? Yes.**

DO: OK. Pero cuando él se salió del carro, tú no viste si él la agarró o no. **OK. But when he got out of the car, you didn't see whether he grabbed it or not.**

JV: No. **No.**

DO: All right. Muy bien. This concludes this interview. Time is 6:32 PM. Ok. gracias **All right. All right. This concludes this interview. Time is 6:32 PM. Ok, thank you.**

Corrected by DSO 4/12/17

Exhibit 3



Complaint No: 20170126131803
Date: 02/03/2017
Type of Case: Murder
Remarks:

Official Report

CONFIDENTIAL: This is an official report of the Charlotte-Mecklenburg Police Laboratory and is to be issued with an official criminal investigation. Do not make public or reveal the contents thereof to any unauthorized person.
The form for this report is found to be in compliance with NCGS 90-95(g) and is hereby approved by the Attorney General.

Items Received

Item 3: 22 LR caliber North American Arms model 22LR-HG five-shot revolver, serial #L159026 which contained four 22 L/LR caliber CCI discharged cartridge cases.

Item 20: Fired bullet fragment.

Item 21: Fired bullet.

Results

The revolver submitted under Item 3 was examined and test fired, and was found to be in good operating condition.

Items 20 and 21 were examined and found to be 22 caliber with an undetermined number of land and groove impressions and direction of twist. Items 20 and 21 were microscopically compared to tests fired from the revolver submitted under Item 3. Items 20 and 21 could neither be identified nor eliminated as having been fired from the revolver due to damage and/or insufficient agreement or disagreement of individual characteristics.

**Authority Kerr Putney
Chief Of Police**

I certify this to be the results of the tests performed on these items.

A handwritten signature in black ink, appearing to read "Gene C Rivera".

**Gene C Rivera
Chief Criminalist**

End of Official Report

Exhibit 4



Complaint No: 20170126131803
Date of Report: 02/03/2017
Type of Case: Murder
Remarks:

Official Report

CONFIDENTIAL: This is an official report of the Charlotte-Mecklenburg Police Laboratory and is to be issued with an official criminal investigation. Do not make public or reveal the contents thereof to any unauthorized person. The form for this report is found to be in compliance with NCGS 90-95(g) and is hereby approved by the Attorney General.

Items Received

Item 31: Buccal standard from Javier Valiente

Item 47: Buccal standard from Josue Javier Diaz

Item 3: Revolver, serial # L159026, with ammunition

Item 3.3: Swabs from the cylinder of the firearm in an area where suspected dried blood was observed

Results

DNA was extracted, quantified, and when appropriate, amplified by the STR polymerase chain reaction (PCR) using the GlobalFiler Kit.

Item 31

A DNA profile was obtained from the buccal standard from Javier Valiente.

Item 47

Presumptive testing for the presence of blood was positive on the buccal standard from Josue Javier Diaz. A DNA profile was obtained from the buccal standard.

Item 3

No serological examinations were conducted on the revolver; however, the grips (Item 3.1) and hammer (Item 3.2) were swabbed separately for DNA. The swab of the hammer was consumed in analysis. The ammunition was not examined.

A mixture of DNA profiles from at least three individuals was obtained from the swabs from the grips of the revolver. A partial major DNA profile can be determined that is consistent with the DNA profile obtained from Josue Javier Diaz. The probability of selecting an unrelated person at random who could be a contributor of this partial major DNA profile is approximately 1 in 319 octillion. Javier Valiente is excluded as a possible contributor of the partial major DNA profile.

A mixture of DNA profiles consistent with originating from two individuals was obtained from the swab from the hammer. A partial major and partial minor DNA profile can be determined.

601 E. Trade St. Charlotte, NC 28202

2/3/2017

Page 1 of 3



Complaint No: 20170126131803
Date of Report: 02/03/2017
Type of Case: Murder
Remarks:

Official Report

CONFIDENTIAL: This is an official report of the Charlotte-Mecklenburg Police Laboratory and is to be issued with an official criminal investigation. Do not make public or reveal the contents thereof to any unauthorized person.
The form for this report is found to be in compliance with NCGS 90-95(g) and is hereby approved by the Attorney General.

The partial major DNA profile is consistent with the DNA profile obtained from Josue Javier Diaz. The probability of selecting an unrelated person at random who could be a contributor of this partial major DNA profile is approximately 1 in 1.4 decillion.

Javier Valiente is excluded as a possible contributor of both the partial major and partial minor profiles.

Item 3.3

Presumptive testing for the presence of blood was positive on the swabs from the cylinder of the firearm in an area where suspected dried blood was obtained. The DNA profile obtained from the swabs matches the DNA profile obtained from Josue Javier Diaz. Given the frequency of occurrence of the DNA profile is rarer than 1 in 700 billion, the evidence supports that Josue Javier Diaz is the source of the DNA profile obtained from the swabs from the cylinder. The swabs were consumed in analysis.

Conclusions

Statistics were calculated using the NIST population database which is published in the May 2013 FSI Genetics, Volume 7, Issue 3, Pages e82-e83. The reported statistics are an estimation for which a deviation of approximately +/- 10-fold may exist.

The most common frequency from the Caucasian, African American, Hispanic, or Asian populations is reported. A source attribution is reported at rarer than 1 in 700 billion and in the absence of a known identical twin.

The partial major DNA profile obtained from the swab from the hammer of the revolver (DNA #17-00407) has been entered into the Combined DNA Index System (CODIS) and will be searched on a periodic basis.

Any remaining material from Items 3.1, 3.2, and 3.3 and all DNA extracts and any remaining extraction material associated with this case will be maintained in the laboratory and transferred to General Biology Storage.

Items 31 and 47 were transferred to the General Biology Cage to be returned to Property Control following examination.

Item 3 was transferred to G. Rivera in the Firearm section for a safety check on 01/27/2017 and was transferred to W. Trantham in the Latent Print section following examination on 01/27/2017.



Complaint No: 20170126131803
Date of Report: 02/03/2017
Type of Case: Murder
Remarks:

Official Report

CONFIDENTIAL: This is an official report of the Charlotte-Mecklenburg Police Laboratory and is to be issued with an official criminal investigation. Do not make public or reveal the contents thereof to any unauthorized person.
The form for this report is found to be in compliance with NCGS 90-95(g) and is hereby approved by the Attorney General.

**Authority Kerr Putney
Chief Of Police**

I certify this to be the results of the tests performed on these items.

Eve Rossi
DNA Team Leader

End of Official Report

Exhibit 5

Mecklenburg County M E Office

3440 Reno Avenue, Charlotte, NC 28216

Telephone 7043362005

Fax 7043368353

REPORT OF AUTOPSY EXAMINATION

DECEDENT

Document Identifier B201700140

Autopsy Type ME Autopsy

Name Josue Chesco Javier Diaz

Age 28 yrs

Race Unknown

Sex M

AUTHORIZATION

Authorized By James R. Lozano MD

Received From Mecklenburg

ENVIRONMENT

Date of Exam 01/27/2017

Time of Exam 10:30

Autopsy Facility Mecklenburg County M E Office **Persons Present** Ms. Linnelle Banks

CERTIFICATION

Cause of Death

Gunshot wounds of the chest and abdomen

The facts stated herein are correct to the best of my knowledge and belief.

Digitally signed by

James R. Lozano MD 02 May 2017 13:24

DIAGNOSES

Gunshot wound of the left upper chest (A), non exiting

Lacerations of the left lung, pulmonary artery, descending aorta, right lung,
diaphragm, liver, and right kidney

Bilateral hemothorax and hemoperitoneum

Gunshot wound of the left chest (B), non exiting

Lacerations of the descending colon

Soft tissue and pericolonic hemorrhage

Gunshot wound of the left upper abdomen (C), non exiting

Lacerations of the stomach, small bowel, and large bowel

Rib fracture

Hemoperitoneum, retroperitoneal hemorrhage

Gunshot wound of the left lower abdominal quadrant (D), non exiting

Lacerations of the descending colon

Left pelvic bone fracture

Soft tissue hemorrhage

Gunshot wound of the left hand (E), exiting the dorsum of left hand

Skeletal fractures

Graze gunshot wound of the left knee (F)

Lacerations of the skin and subcutaneous soft tissue

Abrasion, left knee

IDENTIFICATION

Body Identified By

Papers/ID Tag

EXTERNAL DESCRIPTION

Length 68 inches

Weight 186 pounds

Body Condition Intact

Rigor 2+

Livor Posterior

Hair Black, with a normal pattern of distribution. Facial hair consists of stubble

Eyes Brown

Teeth Natural, in good repair

Received is the body of a well-developed, well-nourished Hispanic man appearing compatible with the reported age of 28 years. The body is received clad in a jacket, T-shirt, pants, underwear, socks, and shoes. Accompanying the body are a yellow metal watch with clear stones, two white metal earrings with clear stones, and a yellow metal eyebrow ring. Identifying marks and scars consist of tattoos on the shoulders, abdomen, upper back, arms, wrists, hands, and right lower leg. There is no evidence of medical intervention.

INJURIES

The following gunshot wounds are lettered for convenience of description. The lettering is not intended to indicate the order in which the injuries occurred.

GUNSHOT WOUND "A":

There is a 3/4" circular entrance gunshot wound on the left shoulder/left upper chest located 9" below the top of the head and 5" left of the anterior midline. There is no evidence of soot or gunpowder stippling noted on the skin surrounding this wound.

The wound track proceeds through the skin and soft tissue of the left upper chest, enters the chest wall between the 2nd and 3rd anterior left ribs, lacerates the left upper lung lobe, the left pulmonary artery, the descending aorta, the right lower lung lobe, the diaphragm, the liver and the right kidney and terminates in the soft tissue of the right abdomen, where a deformed jacketed bullet is recovered.

In the standard anatomical position the projectile travels from front-to-back, left-to-right and downward.

GUNSHOT WOUND "B":

There is a 3/4" x 1/2" elliptical entrance gunshot wound on the left chest located 15" below the top of the head and 5" left of the anterior midline. There is no soot or gunpowder stippling noted on the skin surrounding this wound.

The wound proceeds through the skin and soft tissue of the left chest wall, continues through the soft tissue of the right abdominal wall, lacerates the descending colon and terminates in the soft tissue of the left side of the pelvis where a deformed jacketed bullet is recovered. Injuries associated with this wound include pericolic and retroperitoneal hemorrhage.

In the standard anatomical position, the projectile travels front-to-back, slightly left-to-right, and downward.

GUNSHOT WOUND "C":

There is a 1/2" circular entrance gunshot wound on the left upper abdominal quadrant located 20" below the top of the head and 3" left of the anterior midline. The wound track proceeds through the skin and soft tissue of the left abdomen, fractures the anterior left 8th rib, lacerates the stomach, small bowel and large bowel and terminates in the soft tissues of the left lower back where a deformed jacketed projectile is recovered. The wound track is associated with intra-abdominal and retroperitoneal hemorrhage. In the standard anatomical position, the wound path is front-to-back and slightly downward.

GUNSHOT WOUND "D":

There is a 1/2" in diameter entrance gunshot wound located on the left lower abdominal quadrant located 28 3/4" below the top of the head and 5 1/2" left of the anterior midline. There is no soot or gunpowder stippling noted on the skin surrounding this wound.

The wound track proceeds through the skin and soft tissue of the left lower abdominal wall, lacerates the descending colon, perforates the bone of the left iliac wing, and terminates in the soft tissue of the left buttock where a deformed jacketed projectile is recovered. Associated injuries include soft tissue and intrapelvic hemorrhage.

In the standard anatomical position, the projectile travels from front-to-back and left-to-right.

GUNSHOT WOUND "E":

Located on the posterior left hand at the base of the thumb is a 3/8" entrance gunshot wound located 21" below the top of the left shoulder and 2" left of the posterior midline. There is no soot or gunpowder stippling noted on the skin surrounding this wound.

The wound track proceeds through the soft tissue and bones of the left hand and terminates at an irregular stellate exit wound measuring 2" x 1" and located 21" below the top of the left shoulder and 1" right of the posterior midline of the hand. There is no bullet or fragment of bullet recovered from the wound track.

In the standard anatomical position, the projectile travels from left-to-right.

GUNSHOT WOUND "F":

There is a graze gunshot wound measuring 1 1/2" x 1" on the skin above the right knee located 20" above the left heel and lying along the anterior midline of the left leg. There is no soot or gunpowder stippling noted on the skin surrounding this wound.

The wound track lacerates the skin and superficial subcutaneous soft tissue of the leg. There is no bullet or fragment of bullet recovered from the wound track.

In the standard anatomical position, the projectile travels from right-to-left and slightly downward.

OTHER INJURIES:

There is an abrasion on the surface of the left knee.

DISPOSITION OF PERSONAL EFFECTS AND EVIDENCE

The following items are released with the body

None

The following items are preserved as evidence

The following items are released to Detective Hoppe of the Charlotte-Mecklenburg Police Department on 1/27/2017:

JACKET
TANK TOP
PANTS
UNDERWEAR
SOCKS AND SHOES
VALUABLE PERSONAL PROPERTY
BLOOD STAIN CARD
BULLETS (4)

PROCEDURES

Radiographs

Radiographs reveal radiopaque foreign objects in the right abdomen, left lower back, left pelvis and left buttock.

INTERNAL EXAMINATION

Body Cavities

The pleural and peritoneal cavities exhibit the previously described injuries. The organs are in their normal anatomic positions.

Cardiovascular System

Heart Weight 375 grams

The pericardial sac is free of significant fluid and adhesions. The coronary arteries arise normally, follow the usual distribution and are widely patent without evidence of significant atherosclerosis or thrombosis. The chambers and valves bear the usual size-position relationships and are unremarkable. The myocardium shows no evidence of acute infarction, scarring or focal lesions. The aorta and its major branches show no significant atherosclerosis and exhibit the previously described injuries.

Respiratory System

Right Lung Weight 300 grams

Left Lung Weight 325 grams

Examination of the soft tissues of the neck including the strap muscles and large vessels reveals no abnormalities. The hyoid bone and laryngeal cartilages are intact. The larynx is clear. The upper and lower airways are free of debris and foreign material. The lungs are normally formed. The lungs exhibit the previously described injuries. There is moderate congestion without obvious consolidation or focal lesions. The pulmonary arteries exhibit the previously described injuries but are free of thrombi or emboli.

Gastrointestinal System

Except as previously noted, grossly unremarkable. The stomach contents consist of 200 ml of partially digested food. The gastric contents are present throughout the perigastric area.

Liver

Liver Weight 2250 grams

The liver exhibits the previously described gunshot injury. The gallbladder is present, contains bile, and is grossly unremarkable.

Spleen

Spleen Weight 125 grams

The spleen is normally formed. No focal lesions are present.

Pancreas

The pancreas is of normal size, shape and consistency without focal lesions.

Urinary

Right Kidney Weight 125 grams

Left Kidney Weight 125 grams

Except as previously described, the kidneys are of normal size and shape. The left kidney capsule strips easily from the underlying smooth cortical surface. Except as previously described, the renal architecture is intact. The bladder contains urine.

Reproductive

Grossly unremarkable.

Endocrine

The thyroid gland and adrenal glands are grossly unremarkable.

Neurologic

Brain Weight 1525 grams

Reflection of the scalp reveals no evidence of injury. There are no skull fractures identified. The leptomeninges are thin and delicate. The cerebral hemispheres are grossly unremarkable. The vasculature at the base of the brain is intact and without significant atherosclerosis. Coronal sections reveal a normal architecture without focal lesions.

Skin

Except as previously noted, grossly unremarkable.

Immunologic System

Grossly unremarkable.

Musculoskeletal System

Except as previously noted, grossly unremarkable.

MICROSCOPIC EXAMINATION**Microscopic Comment**

Histologic examination is not performed.

SUMMARY AND INTERPRETATION

The decedent is a 26-year-old man who was shot.

Autopsy examination reveals six (6) gunshot wounds resulting in numerous organ system injuries.

Postmortem toxicology reveals the presence of alprazolam, cocaine, and benzoylecgonine, a metabolite of cocaine, in the decedent's blood. Please see separate report (T2017-1089) for further details.

Based on the history, autopsy findings, and results of postmortem toxicology, it is my opinion that the cause of death in this case is gunshot wounds of the chest and abdomen.

DIAGRAMS

1. BODY DIAGRAM: ADULT (FRONT/BACK)
2. BODY DIAGRAM: ADULT (FRONT/BACK) HEAD (LEFT/RIGHT)

State of North Carolina

Name of Decedent: JOSUE DIAZ

Office of the Chief Medical Examiner

Autopsy # B17-140

Chapel Hill, North Carolina 27599-7580

Examined By: JBL

Date: 1-27-17

BODY DIAGRAM: ADULT (Front/Back)

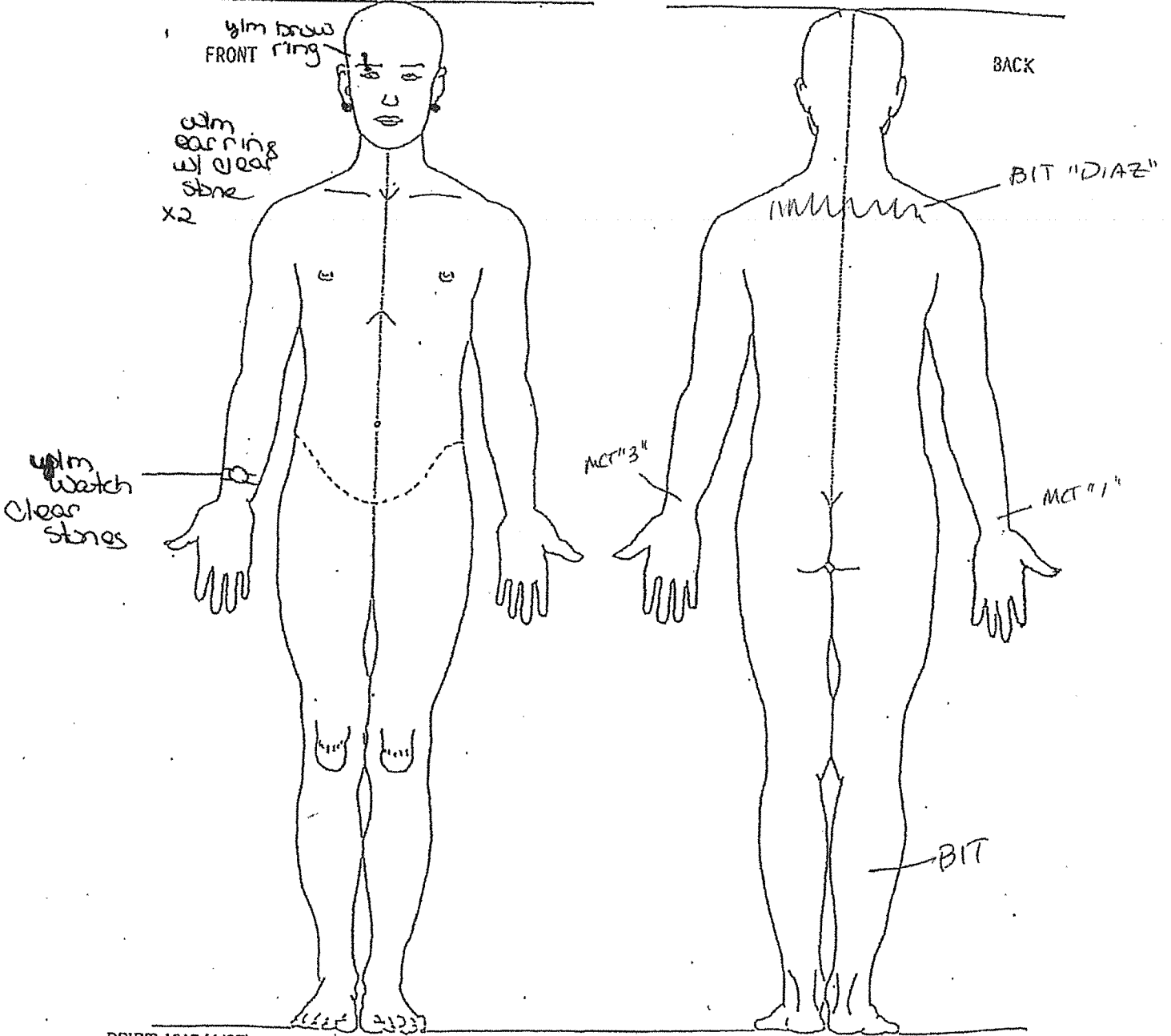

DEHR 1917 (4/87)
Medical Examiner

This form may be photocopied.

PAGE 1 OF 2

B# 17-140
 Josue Diaz

BODY DIAGRAMS

Legend:	
A= Abrasion	G= Gunshot
B= Burn	L= Laceration
C= Contusion	S= Stab

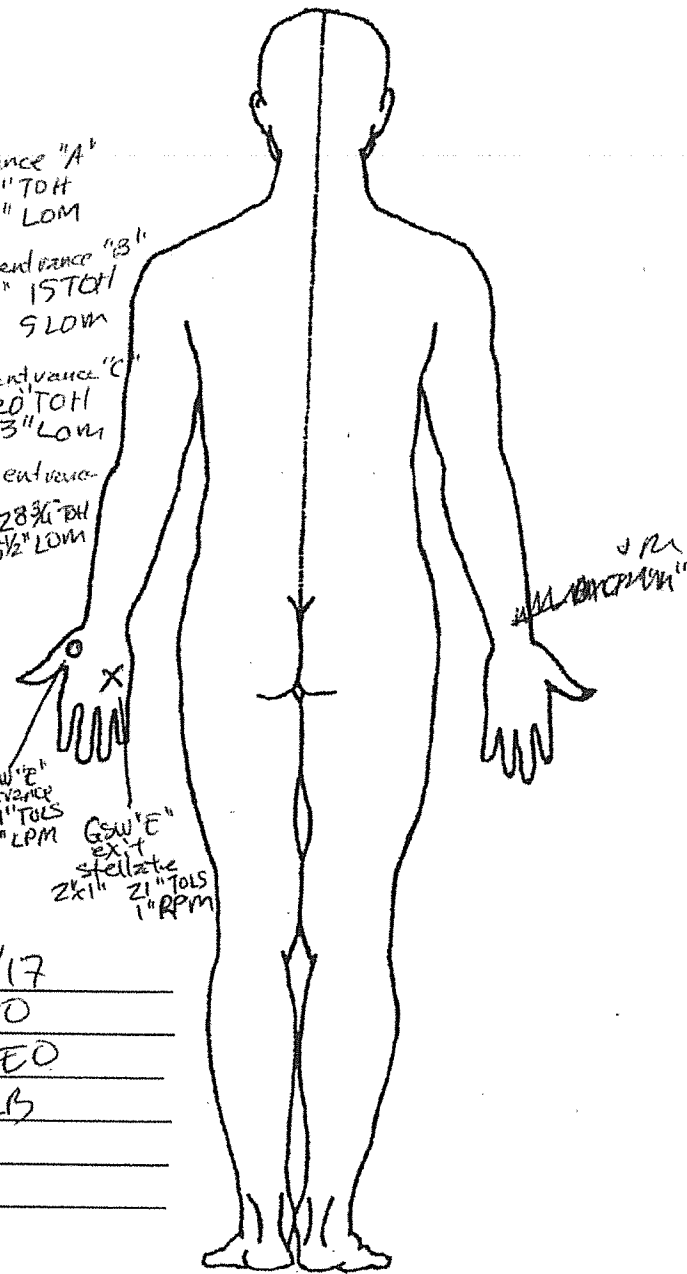
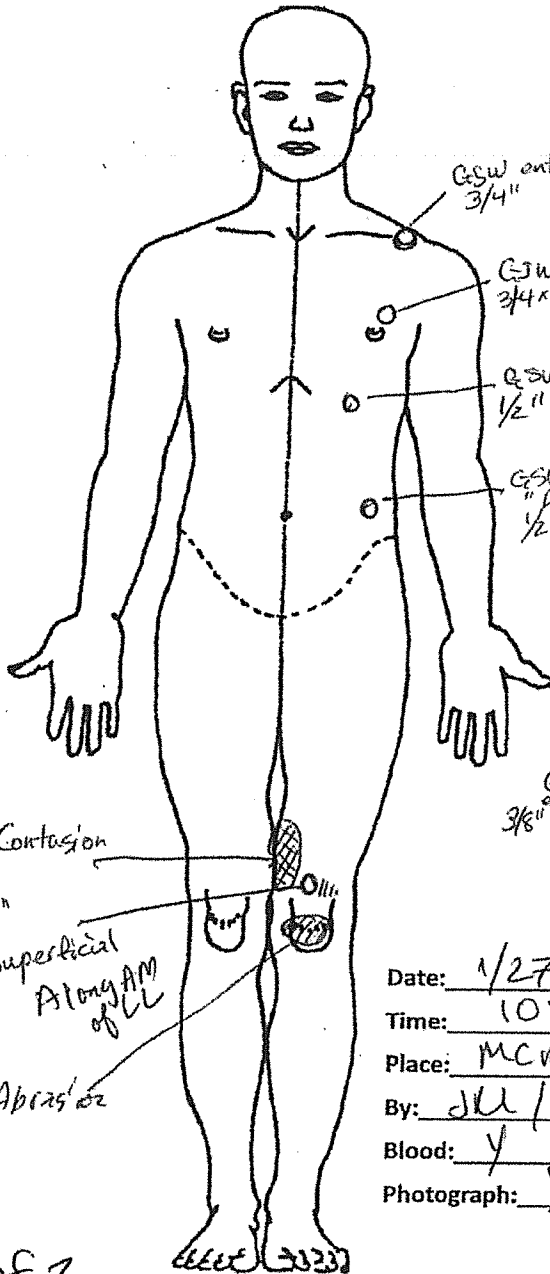
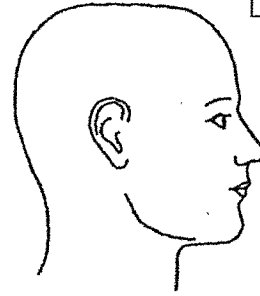
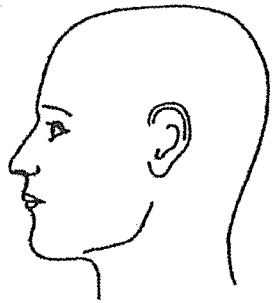

Date: 1/27/17
 Time: 1030
 Place: MCMED
 By: JLU/LB
 Blood: y
 Photograph: y

2 of 2

Indicate nature, location and measurements of wounds and other lesions (scars, tattoos, medical therapy, etc.) on these diagrams (Not to scale)